



# Property Risk Consulting Guidelines

XL Risk Consulting

A Publication of AXA XL Risk Consulting

PRC.4.0.3

## PROCEDURES FOR LEAK TESTING SAFETY SHUTOFF VALVES

### INTRODUCTION

Fuel gas fired equipment codes and standards require the fuel gas safety shutoff valves to be leak tested. The boiler codes stipulate that the valves should be tested on a monthly basis. The oven codes state the valves must be tested at least annually.

A leaking valve could allow gas to accumulate in the combustion chamber and explode. If the gas train is equipped with double safety shutoff valve and vent line, a leaking safety shutoff valve could allow the gas to vent to the atmosphere through the vent line, increasing the cost of operating the unit.

### POSITION

Conduct and record leak tests of all safety shutoff valves on a monthly basis. Conduct the test when the unit is shut down.

The suggested testing procedure is: (See Figure 1 for the schematic location of the numbered safety equipment.)

1. Close the manual shutoff valve (10) downstream of the second safety shutoff valve (7).
2. Energize the vent line valve (6) to close it. (On multi-burner units, the header vent valve must also be closed.)
3. Start with the upstream safety shutoff valve (4). Remove the cap from the test cock (5) and place a rubber hose on the cock, place the other end of the hose in a bucket filled with water, and open the test cock. Be careful not to immerse the hose too deep, as the gas pressure might be less than 1 in. (2.5 mbar) of water. If bubbles appear in the bucket, the valve is leaking. Shut the test cock and replace the cap.
4. Open the upstream safety shutoff valve (4) by either energizing the valve, or manually opening the valve keeping the vent line valve (6) closed (energized).
5. Remove the cap from the test cock (8) and place a rubber hose on the cock, place the other end of the hose in a bucket filled with water, and open the test cock. Again, be careful not to immerse the hose too deep, as the gas pressure might be less than 1 in. (2.5 mbar) of water. If bubbles appear in the bucket, the valve is leaking. Shut the test cock and replace the cap.
6. Shut the upstream safety shutoff valve (4) and de-energize the vent valve (6) allowing it to open. Open the manual shutoff valve (10) downstream of the safety shutoff valve.

If a safety shutoff valve has leaked, clean it internally and repair as necessary. Keep records indicating the valve test date and its condition.

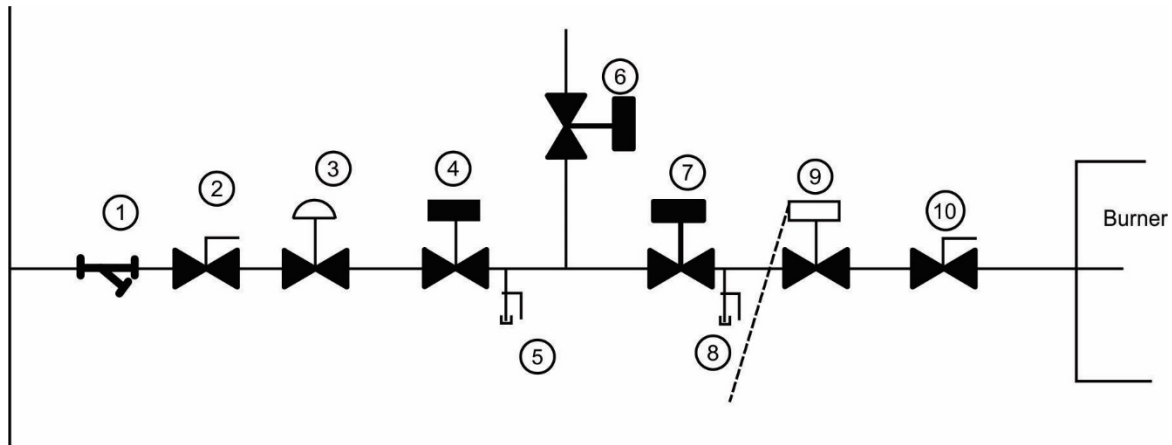

- |  |  |
|--|--|
| 1. Strainer/Drip Leg                       | 6. Vent Valve and Vent Line to Atmosphere    |
| 2. Upstream Manual Shutoff Valve           | 7. Downstream Safety Shutoff Valve           |
| 3. Gas Regulator                           | 8. Downstream Leak Test Connection and Valve |
| 4. Upstream Safety Shutoff Valve           | 9. Modulating Valve                          |
| 5. Upstream Leak Test Connection and Valve | 10. Downstream Manual Shutoff Valve          |

Figure 1. Safety Equipment Location.