



Property Risk Consulting Guidelines

XL Risk Consulting

A Publication of AXA XL Risk Consulting

PRC.17.6.1

PROTECTION FOR HIGH-RISE BUILDINGS

INTRODUCTION

For the purposes of this document a high-rise building is one in which fires must be fought internally because of height, i.e., the upper stories are beyond the effective reach of fire department aerial equipment commonly considered to be 75 ft (23 m). This document does not cover the protection of atriums. The general occupancies of these high-rises are offices with attendant support areas and/or residential areas, such as apartments, hotels, and condominiums. Lower floors may be occupied by casinos, shops or a parking garage while the top floors may house clubs or restaurants.

Fire protection philosophy for high-rise buildings must recognize and reflect the impediments and difficulties these structures inherently impose upon fire department operations. The logistics of gaining access to the building, placing personnel and equipment on the upper floors, the need for effective smoke control, and the increased dependence upon the building's facilities (elevators, standpipes, air conditioning systems, booster pumps, etc.) all emphasize the importance of internal protection features and the resultant need for a coordinated and conservative approach in their design.

The guidelines offered are for the protection of property. No attempt has been made to cover the detailed aspects of life safety although it is generally recognized that comprehensive protection of property has a significant, positive influence upon the security of the building occupants.

All high rise buildings must meet specific protection, emergency planning and staff training requirements as defined by various jurisdictional codes, which may supersede the recommendations set forth within this guideline. Reference should be made to code requirements set forth by the jurisdictional authorities, which may govern the metropolitan area of the high-rise building.

HUMAN ELEMENT PROGRAMS

Establish human element and maintenance programs as outlined in *OVERVIEW* (also found in PRC Guideline Sections 1). Supplemental information specific to high-rise buildings is provided as follows:

Pre-Emergency Planning

Station a person knowledgeable of the building construction, occupancy, and fire protection features at the building command center to assist and direct the public fire department. Knowledge of the heating ventilation and air condition (HVAC) system and smoke control systems is essential.

One of the most frequent causes of property loss within a high rise building is a domestic water loss. Provide a documented plan for domestic water emergencies listing all domestic water control valves and the areas they control. Make this plan accessible to all maintenance, security and custodial

personal. The plan should accurately describe the location of the valves within the facility. A well developed, documented and practiced emergency response plan for domestic water emergencies can mean the difference between a minimal or severe water loss to the facility.

Fire Protection Equipment Inspections & Testing

Inspect the fire alarm and smoke control systems (if applicable), including shutdown devices for proper operation by adequately trained personnel at least every six months. Ensure that all equipment requiring servicing and testing is readily accessible, and provided with a practical means for cleaning. Provide sufficient instrumentation for testing and maintenance. In particular, examine the following equipment:

- Inspect system activating devices, such as fusible links or heat or smoke detectors, to see that they are not covered with residue or are otherwise impaired.
- Test the fire and smoke dampers at a minimum every 2 yr to detect damage, obstructions and, corrosion. (See NFPA 90A for maintenance practices.)
- Test the heat and smoke detection systems every six months by simulating emergency mode conditions. If the manufacturer's or installer's recommendations are for a more frequent timeframe, then test per their instruction.
- Maintain, inspect, and test the fire pumps, sprinkler systems and standpipe systems in accordance with NFPA 25 (weekly pump churns, monthly visual sprinkler valves, quarterly waterflow and valve tamper test, and all devices tested annually). All equipment and controls should be clearly identified.
- Maintain, inspect, and test pressure reducing valves in accordance with NFPA 25. Size the drainage system to allow for proper testing of these valves.

Housekeeping

Do not allow storage in non-sprinklered areas. Pay special attention to the evaluation of unnecessary combustibles in electrical, mechanical, telephone, UPS and other critical equipment rooms.

AUTOMATIC AND MANUAL PROTECTION FEATURES

Sprinkler Protection

Provide automatic sprinklers on wet-pipe systems throughout the building. Install sprinklers in accordance with NFPA 13 and PRC.12.1.1.0. using the following hydraulic designs:

- Residential Floors: Design for a Light Hazard occupancy using a density of 0.10 gpm/ft² over the hydraulically most remote 1500 ft² (4.1 mm/min over 139 m²) - if the area meets the intent of light hazard occupancy.
- Typical Office Spaces: Design for an Ordinary Hazard - Group 1 occupancy using a density of 0.12 gpm/ft² over the hydraulically most remote 3000 ft² (4.9 mm/min over 279 m²) or 0.15 gpm/ft² over the hydraulically most remote 2000 ft² (6.1 mm/min over 186 m²).
- Computer Rooms & Restaurant Service Areas: Design for an Ordinary Hazard - Group 1 occupancy using a density of 0.12 gpm/ft² over the hydraulically most remote 3000 ft² (4.9 mm/min over 279 m²) or 0.15 gpm/ft² over the hydraulically most remote 2000 ft² (6.1 mm/min over 186m²).
- Mercantile (Retail) Areas: Design for an Ordinary Hazard - Group 2 occupancy using a density of 0.17 gpm/ft² over the most hydraulically most remote 3000 ft² (6.9 mm/min over 279 m²).
- Mechanical Rooms, Tape Vaults, File Rooms and Department Stores: Design for an Ordinary Hazard - Group 2 occupancy using a density of 0.17 gpm/ft² over the most hydraulically most remote 3000 ft² (6.9 mm/min over 279 m²).

- Lodging facilities, Restaurant Seating Areas: Light Hazard. Design for a minimum of 0.10 gpm/ft² over the hydraulically most remote 1500 ft² (4.1 mm/min over 139 m²) - as long as the area meets the intent of light hazard occupancy.
- Parking garages: Refer to PRC.17.14.3.

Provide a minimum of 250 gpm (950 l/min) for interior hose demands.

Do not exceed 130 ft² (12.1 m²) for the typically sprinkler head, however, up to 225 ft² (20.9 m²) spacing may be considered acceptable if the overall combustible loading is low, construction is favorable (concrete), and the occupancy is unlikely to change.

Where possible, use dual sprinkler feeds for each floor, or staggered feeds – feeding floors alternately from two risers – so that the impairment of a single riser has minimum to no impact. An entire riser could be taken out with no impact to the building's protection if using dual feeds into a single system or loop on each floor. If two separate systems are being fed by two different risers per floor, only half of each floor would be impaired. With staggered feeds, only every other floor would be impaired.

Do not use the “Room Design Method” outlined under NFPA 13.

Pressure Reducing Valve (PRV)

Make every reasonable effort to design high-rise water supplies to avoid the need for pressure reducing valves by using a zoned approach. Failure of a pressure reducing valve can result in over-pressurization of sprinkler systems and possible sprinkler leakage. Improper size or setting of a pressure reducing valve can restrict sprinkler system pressure below that which is needed for adequate protection.

If pressure reducing valves cannot be avoided, install them in accordance with NFPA 13. Pay particular attention to the following key requirements:

- PRV is properly sized for the application
- Drain is adequately sized for partial flow tests
- Pressure gauge is installed at least on the outlet side of the valve
- Valve setting pressure is posted on a placard or other suitable label

Water Supplies

Provide two connected water sources at ground level, each capable of meeting the combined maximum sprinkler and hose stream demand for at least one hour. Arrange the pump installation in accordance with [Figures 1](#) through [4](#).

EXCEPTIONS: For buildings up to 250 ft (76 m) high, one connected source may be acceptable if all risers are equipped with fire department connections, the site is under the jurisdiction of a public fire department and the fire department pumper source will not be impaired at the same time as the connected supply. This single source cannot be a ground level tank supplying a fire pump. If public mains supply a booster pump, design the sprinkler systems protecting the lower floors and areas where the floors are open to each other based on public water supply without the booster pump in operation. Lower floors are those floors that contain shops, stores, restaurants, ballrooms, meeting rooms and parking garages. Examples of floors that are open to each other are lobbies, open escalators and atriums.

Two independent connections from a public water supply may be acceptable as the sources to fire or booster pumps. This is acceptable provided any single break in the public water system does not reduce the water supply to the booster pumps to the point where the pump discharge is below the sprinkler system demand.

Arrange all fire and booster pumps for automatic operation upon drop in pressure. If possible, arrange for manual remote starting capability at the security control center. For pumps arranged in accordance with [Figure 1](#), provide a dual setting pressure switch on each zone. Set the upper pressure setting on Zones 1 and 3 to start Pump 1 and the lower setting to start Pump 3. For Zones 2

and 4, set the arrangement to start Pump 2 first then Pump 3. Arrange the manual remote start to start the pumps in this order.

Arrange fire and booster pumps for manual shutoff only. Pump run timers should be disabled when in use as they can lead to premature pump shut down, or an on-off cycling of the pump that can lead to pump damage.

Design all fire and booster pumps, including those in upper zones and those in series, to have flooded suctions by way of connection to a public water supply or from a suction tank. Size suction tanks for a two hour water supply. Size holding or “break” tanks supplying fire pumps in upper zones to supply the sprinkler demand for 30 min. Arrange the tanks to be filled by a float-operated, over-the-top connection from the zone below, as well as a float-operated connection to the building’s domestic supply. The flow rate from either source should not be less than the anticipated sprinkler or hose stream demand, whichever is greater.

Provide diesel engine-driven fire pumps or booster pumps with an eight hour fuel supply. If electric pumps must be used, provide two independent sources of electric power or diesel generator backup power with an eight hour fuel supply.

High-Rise Gravity Tanks

Frequently, high-rise gravity tanks feed both domestic and fire protection water supplies and are arranged with a specified volume for fire reserve. Dedicated fire protection tanks, however; are also not uncommon.

Fill gravity tanks automatically from service (house) pumps, activated by float or pressure switches. If this cannot be done, ensure that written programs are in place to ensure reliable manual fill. Connect service (house) pumps to the emergency generators for the building.

Size gravity tanks to meet the sprinkler demand for a minimum of 30 min. For combination fire and domestic water supply tanks, size fire volume to meet the sprinkler demand for a minimum of 30 min.

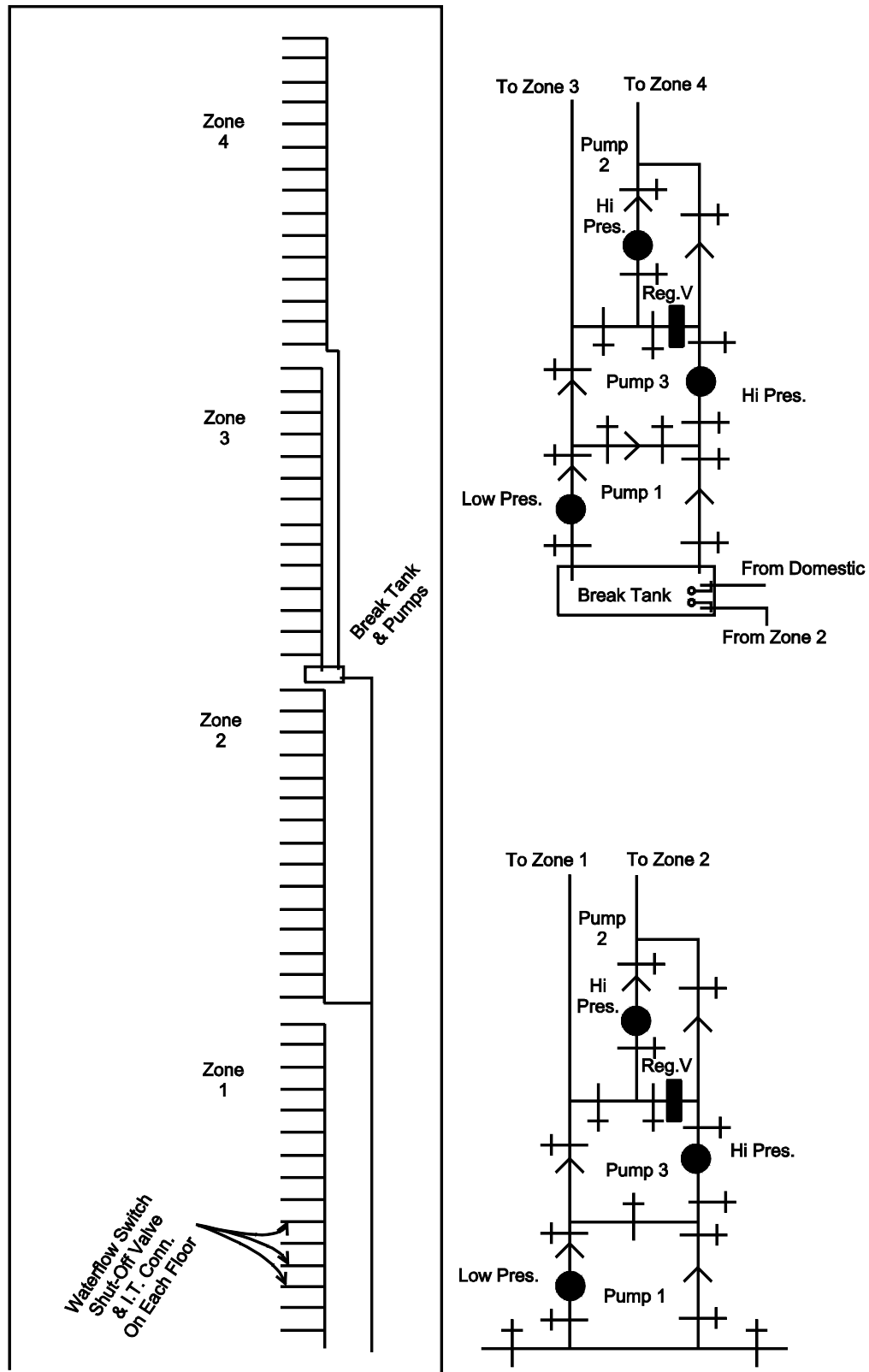

Figure 1. Pump and Piping Arrangement Utilizing Pumps In Series For Higher Elevations.

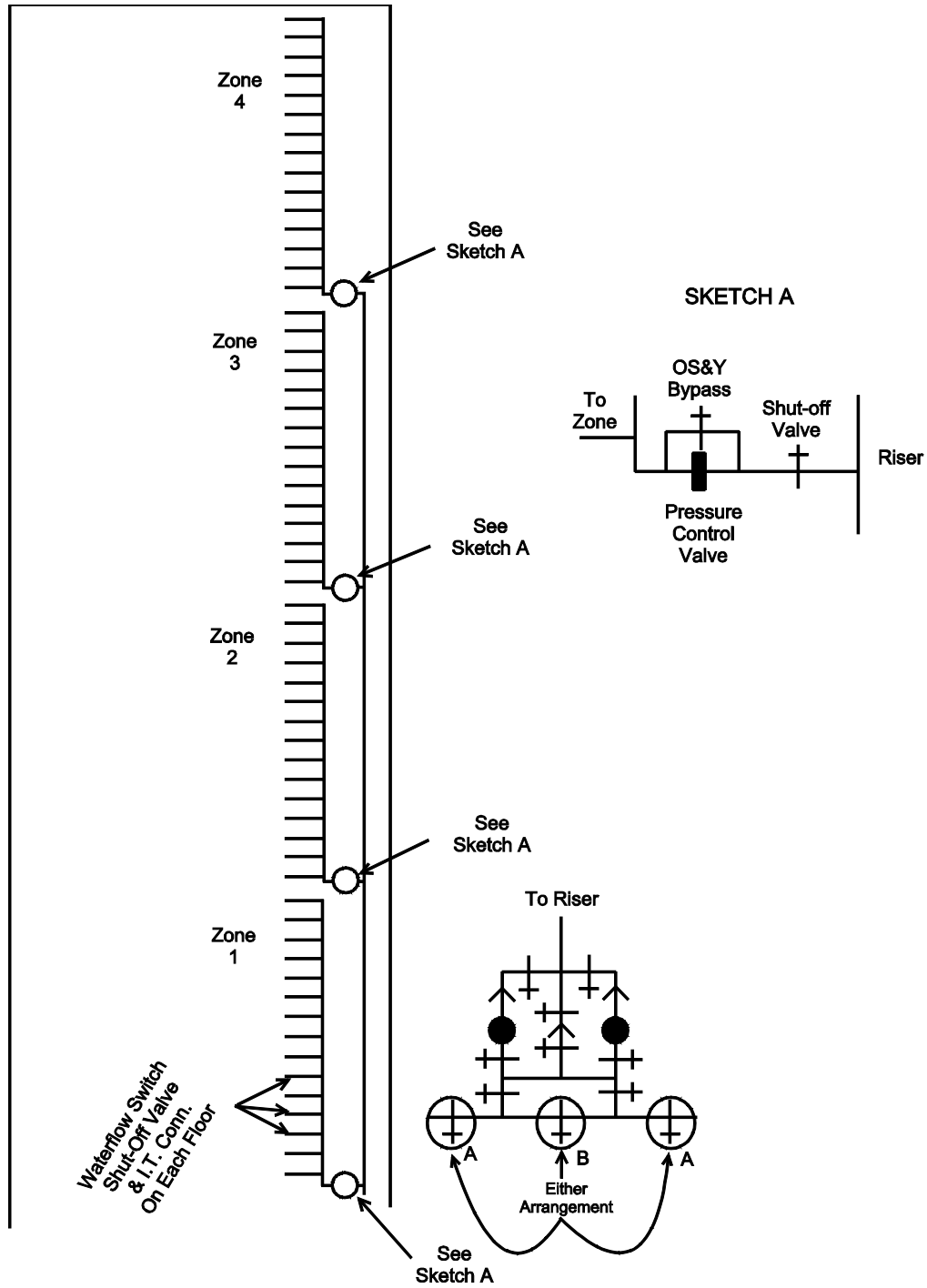

Figure 2. Pump and Piping Arrangement Utilizing High Pressure Pumps.

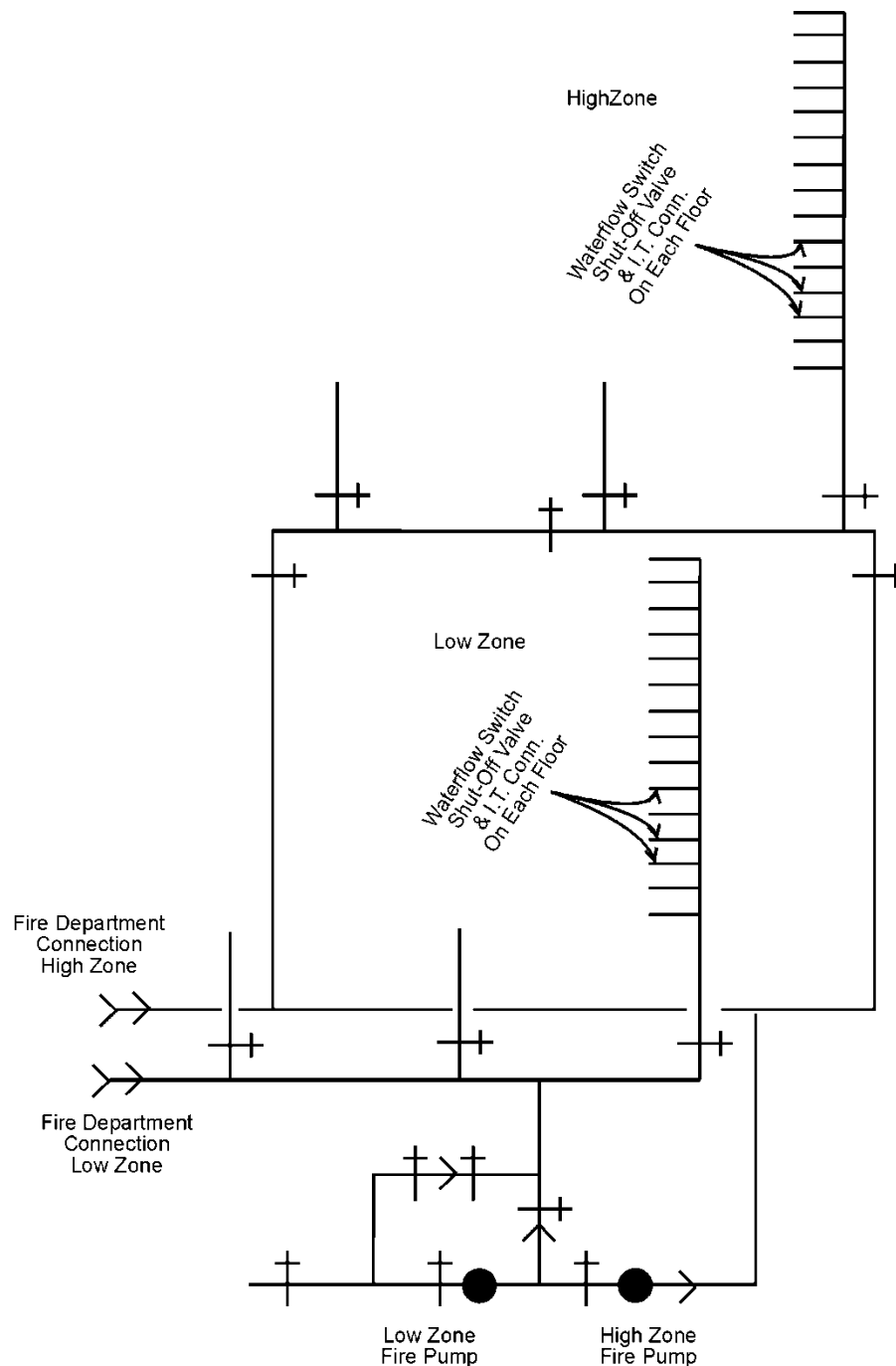

Figure 3. Pump and Piping Arrangement for Dual Zones.

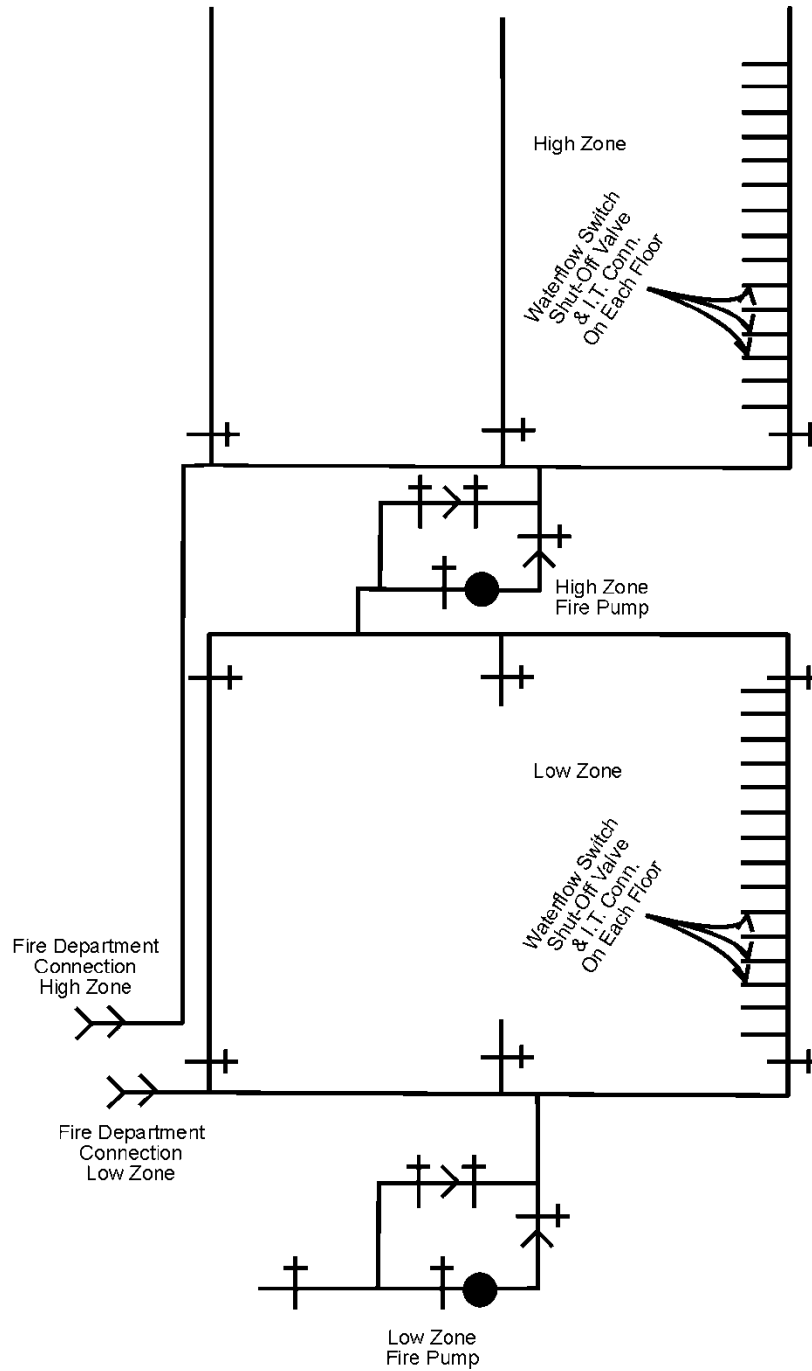

Figure 4. Pump and Piping Arrangement for Dual Zones.

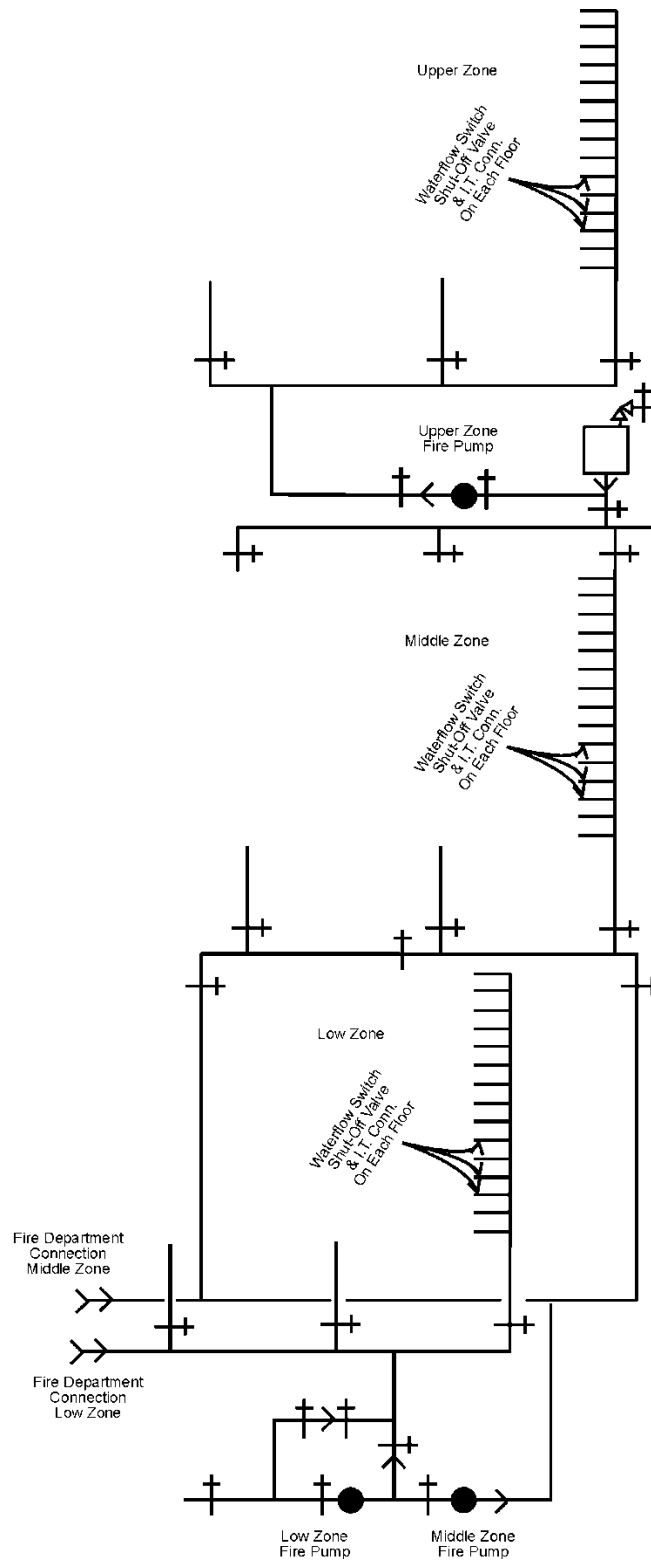

Figure 5. Pump and Piping Arrangement for Three Zones.

In Figures 1 and 2, the risers servicing Zones 2 and 4 need be of 300 psi (20.7 bar) service for the first 250 ft (76 m) of their length or where anticipated pressures would exceed 150 psi (10.4 bar).

Provide a separate shut-off valve and water flow switch on each sprinkler system on each floor. In addition, provide at each system, a placard indicating the hydraulic design.

NOTE: When selecting a pressure reducing valve as shown in Figure 2, use one that responds to outlet pressure, i.e., one that operates independently of the inlet pressure. These are often referred to as pressure control valves or a pilot operated pressure control valve. Do not use direct acting types that respond to inlet pressure. On retrofits it may be necessary to use UL Listed "Special System Water Control Valves - Class II (VLMT)" to control the water pressure from an existing standpipe and pumping system at the 175 psi (12.1 bar) maximum permitted by NFPA 13.

Provide a fire department connection on all risers at grade level (sprinkler, standpipe, or combined) with each labeled as to the system it services.

Divide the building into zones at vertical intervals not exceeding 250 ft (76 m) in height. Design each zone to be supplied from two sources of water.

EXCEPTION: One source may be acceptable for the first zone. (See Exception under Water Supplies.)

High pressure express mains may be used to supply intermediate zones and pumps may be used in series to develop the high pressure for such mains. Design the zones and select pumps so that pressure reducing valves are not needed to supply the sprinklers at the individual floors. Sprinklers, valves, water flow devices, and other components of the fire protection systems must not be subjected to pressure in excess of 175 psi (12.1 bar) including static or pump churn pressures unless all of them are listed for a higher pressure service.

Standpipes

Locate, size, and arrange standpipes in accordance with NFPA 14 for Class III service. Combined standpipe/sprinkler systems may be the more economical and are acceptable.

Protective Signaling Services

Provide a central station signaling system, proprietary signaling system, or a combination of the two, covering sprinkler water flow, sprinkler and water supply control valves, fire pump power supplies and running conditions, water tank levels, and temperatures. Indicate the location of all operating flow devices on an annunciator located at the constantly attended, building security control center. Locate an annunciator panel at the street level; otherwise clearly identify the center at street level for immediate fire department guidance.

Provide smoke detectors as follows:

- In the air-conditioning return-air ducts on all floors.
- In every mechanical equipment rooms, telephone and electric closets.
- In corridors, hotel rooms, and apartments on residential floors.
- Annunciate the operation of any smoke detectors on the central control panel.

Smoke Control

Provide a manual override of air-conditioning controls at the security control center. Interlock the air-conditioning systems so that the operation of any detector or sprinkler will automatically place the air-conditioning systems into a prescribed mode for smoke control. The preferred method of control is by providing full exhaust on the fire floor and pressurization of adjacent floors above and below, i.e., no recirculation.

Emergency Generator Diesel Fuel Systems

Diesel Fuel Storage Tanks

Locate fuel storage tanks inside minimum 2 h fire rated cut-off rooms or vaults; preferably on the first floor. Construct fuel tank supports from fire resistive materials. Protect plain steel supports with a fire-resistive coating or automatic sprinklers beneath the tank.

Provide secondary containment for fuel tank rooms, sized to handle at least 110% of the capacity of the largest single tank in the room.

Use top-connections to fuel storage tanks for all fill, vent and discharge piping connections. When existing bottom-connections cannot practically be relocated, provide fusible link-actuated safety shutoff valves, located immediately between the tank connection and the piping. Provide a reliable means of preventing tank overflow.

Protect tank rooms/vaults with automatic sprinklers designed to provide a minimum density of 0.30 gpm/ft² (12.2 mm/min) over the entire room/vault with preference given to a foam/water. It has been proven that automatic sprinkler protection alone cannot extinguish a fire with flash points under 200°F (93°C). Sprinklers may cool or contain, but not extinguish

Diesel Fuel Distribution Pumps

Locate fuel distribution pumps inside a minimum 2-hour fire rated cut-off room. Provide automatic sprinkler protection in the fuel pump room. For pumps that are located in other areas, provide automatic sprinklers directly over the pumps and extending 15 ft (4.6 m) in each direction beyond the footprint of the pumps. Provide secondary containment for fuel pumps using minimum 3 in. (75 mm) high curbing or metal containment pans.

Provide leak detection within the secondary containment of the pumps that will shut down the pumps. Interlock pumps to shutoff upon leak detection. Other means, such as heat detection, waterflow, etc. may be used as an interlock other than leak detection. The main goal is to shut down and isolate the fuel supply in the event of a major fire or other unforeseen event.

Provide fusible-link actuated safety shutoff valves on the suction side of fuel pumps. Provide an anti-siphon valve between the tank discharge and the pumping system.

Diesel Fuel Distribution Piping

Use seamless steel piping with welded fittings for distribution of diesel fuel. Flanged or threaded fittings are acceptable inside generator or fuel pump rooms having secondary containment and interlocked leak detection. Flanged or threaded fittings are also acceptable if the piping itself is equipped with secondary containment and interlocked leak detection.

Use concentric (secondary containment) piping for pipe runs outside of cut-off fuel pump or generator rooms. Provide a built-in well at the low-point of concentric piping with interlocked detection within the well. Single-wall, seamless steel piping with welded fittings may be used within fire-rated pipe chases. Provide fusible-link actuated safety shutoff valves on the fuel piping where it enters generator rooms.

Diesel Fuel Day Tanks for Generators

Locate day tanks within dedicated tank rooms, generator rooms or mechanical equipment rooms that are cut-off from adjoining occupancies by minimum 2 h fire rated construction. Provide secondary containment for day tanks, sized for 110% capacity of the largest day tank within the containment area. When large diameter pipes are used to create a fuel header that serves as the day tank for one or more generators, provide secondary containment for the generator room, sized to handle 110% capacity of the header.

Providing the generator does not provide power for life safety equipment, install fusible-link actuated safety shutoff valves on bottom-connections to day tanks. Provide an anti-siphon valve between the tank discharge and the pumping system. Provide automatic sprinklers directly over the day tanks and extending 15 ft (4.6 m) in each direction beyond the footprint of the tanks. Provide a reliable means of preventing tank overflow.

Diesel Emergency Generators

Locate generators within dedicated generator rooms or mechanical equipment rooms that are cut-off from adjoining occupancies by minimum 2 h fire rated construction. Install a fusible-link actuated safety shutoff valve on the fuel supply piping to each generator, just upstream of any flexible fuel supply hose that feeds the generator. Provide automatic sprinklers directly over generators and extending 15 ft (4.6 m) in each direction beyond the footprint of the generators. Replace flex hoses with metal jacketed hoses on generator.

Miscellaneous

Program all elevators for automatic recall to the lobby floor upon the actuation of any smoke detector or other fire alarm. In addition, arrange the elevators to be capable of being controlled by emergency keys that will divorce the units from the normal electronic call button use. Designate a freight elevator specifically for fire department use, to be controlled manually by a special key made available to fire department personnel.

Provide two-way voice communication system from every floor to the central security and alarm center.

Provide emergency power sufficient to operate elevators, particularly the freight elevator designated for fire department use, for emergency lighting, the smoke removal system, electric fire pumps, and alarm and communication systems.

Retain a set of drawings at the central security and alarm center detailing water supply and sprinkler control valve arrangements, sprinkler coverage and hydraulic design, air conditioning fan and damper interlocks, smoke and heat detector identification and location and other pertinent design information that is needed as reference on the security and protection system of the building.

DISCUSSION

General

High-rise buildings inherently have a fire resistive structural frame as required by building codes. Leniency or variations in the interpretation and application of these codes may be allowed by some jurisdictions in recognition of, and as an encouragement to, the provision of sprinkler protection.

These so-called "trade-offs," however, should not affect the integrity or fire resistance of the main structural frame. The first two or three floors of some high-rise buildings may be open to each other and serviced by escalators as well as stairs and elevators. Upper floors, however, are generally intended to be cut off from each other with passageway between floors accomplished through cut-off stair towers and elevator shafts. Unless particular care is taken during the course of construction and in the later use of the building, the intended floor cutoffs may be compromised by floor slab penetration created by the installation of conduits, cableways, or ducts. Listed penetration fittings or the use of sealing systems of adequate fire resistance are needed in all cases to maintain the intended vertical separation of fire areas.

Special attention and consideration are also needed for the modern, glass walled, skyscraper. Inadequate mating or closure between the floor slabs and perimeter walls may occur either as an oversight on the construction drawings or the lack of attention to finishing details. The floor cutoffs may also be circumvented by heat and flames surging up the side of the building and entering upper stories by radiation and convection through heat-shattered windows.

Sprinklers

Experience has shown that in the long term it is difficult to control the occupancy fire load. As tenants redecorate, refurbish, or renovate, additional combustibles tend to accumulate in the form of paneling, upholstered furniture, plastic shelving and decorations, open files, etc. There also are changing needs for storage space, display areas, computer expansion, etc. For these reasons, AXA XL Risk Consulting advocates that the protection for general office areas be designed for Ordinary Hazard,

Group 1 instead of the Light Hazard occupancy that is based on minimal combustibles loading. By so doing, greater flexibility is provided in the use of general areas, reinforcement of protection is more readily achieved if needed, and a small safety factor is allowed for weaknesses or increased hazards that may develop unnoticed.

Design sprinkler systems so that pressure reducing valves are not required on each floor to maintain pressures less than 175 psi (12.1 bar). Most of the valves listed for this purpose respond to the inlet pressure and are referred to as the "direct acting type." To adjust these valves properly, the inlet pressure, required outlet pressure, and the required flow rate must be known. If the inlet pressure falls below the design, the outlet flow and pressure may be inadequate to supply the sprinkler demand.

When the design requires a pressure reducing valve to be installed, use a pilot operated pressure control valve or other type that reacts to the outlet pressure. These valves will maintain the desired outlet pressure regardless of the inlet pressures and flow rates, and will open fully when the inlet pressure falls below the desired outlet pressure. For additional information, see PRC.12.1.1.0.

Water Supplies

As buildings rise above the height to which normal fire department pumpers can provide water at a usable pressure, i.e., above 250 ft (76 m), fire protection becomes totally dependent upon internal water supplies. To satisfy this dependency, water can be provided to upper zones by high pressure pumps, 175 to 400 psi (12.1 to 27.6- bars), by series pumping or a combination of both. The difficulty in relying solely upon high pressure pumps is the subsequent need for pressure reducing valves on those floors where water pressure is above a desirable level for sprinklers and hose streams, i.e., above 175 psi (12.1 bar).

By whatever arrangement water is provided to the upper zones, failure of a single pump should not completely impair the sprinkler and hose stream protection. This requires parallel or spare pumping capability, or stored water arranged to backfeed the sprinkler systems whenever the pumps are out of service.

Smoke Control

The adaptation or design of air conditioning and ventilating systems for effective smoke control will be influenced by the overall building design, occupancy, and degree of compartmentation and must reflect such important considerations as planned egress routes, places of refuge, and exist door pressures.

Appendix C of NFPA 90A discusses the basic concepts for smoke control and offers general guidelines and a list of pertinent references on the subject.

Public Fire Department

The possibility of impaired or ineffective sprinkler protection must be considered. The end result is ultimate reliance upon the public fire department. With the logistical problems that are inherent to manually fighting fires in the upper zones of high-rise structures, it is essential that there be good coordination and cooperation between the fire department and the building security and maintenance forces. The fire department's effectiveness will be governed to a major extent by building equipment pumps for water in the upper floors, elevators for the transportation of men and equipment, air conditioning for smoke control, standpipes for hose hookup, and intercommunication systems for message handling.

With the interdependency that exists, there should be periodic familiarization tours and discussions, covering all fire detection and protection systems and equipment, for fire department personnel on all shifts, and scheduled test and maintenance programs for building security and maintenance department.