



Property Risk Consulting Guidelines

A Publication of AXA XL Risk Consulting

PRC.10.1.2.1

MAXIMUM RELIABILITY FOR HIGH RACKED STORAGE PROTECTION

INTRODUCTION

MAXIMUM RELIABILITY denotes a carefully coordinated protection design that ensures reasonable control of fire in high racked storage facilities despite any credible **single** impairment, such as an impairment to a water supply or a valve closure to any interior or exterior piping.

Rack heights have increased above 25 ft (7.6 m) and aisles have become narrower, i.e., less than 8 ft (2.4 m). Racks are also longer, i.e., over 150 ft (46 m). These dimensional changes have so restricted manual firefighting capabilities that total reliance must be placed upon sprinkler protection for initial control. This fact provides the rationale for using the MAXIMUM RELIABILITY approach. Accordingly, to avoid total loss to a warehouse, minimum acceptable in-rack sprinkler protection must be maintained under any reasonably adverse circumstance.

NFPA 13, like most consensus documents, represents minimum acceptable guidelines for protection of property against fire. The document is not designed to reflect special considerations, such as the probable performance under adverse or unusual conditions or the increased reliability necessary for high valued property.

Most high rack storage facilities represent high content values. More importantly, sophisticated and efficient storage and retrieval capabilities may be critical to order filling, to general flow of materials, and to production scheduling. Unique fire protection problems presented by rack storage above 25 ft (7.6 m) include the design of the fire walls, the building structural elements, and the ability of the rack supports to sustain the additional weight of wet stock. Thus, the MAXIMUM RELIABILITY concept could reduce the extent of damage should a fire occur.

POSITION

Figures 1 through 17 illustrate MAXIMUM RELIABILITY arrangements for water supplies, exterior and interior piping, and in-rack sprinkler placement.

This guideline applies to Class I through IV, cartoned expanded Group A plastic and cartoned unexpanded Group A plastic commodities. Open top combustible containers and exposed Group A plastic are outside the scope of this guideline.

All sprinkler systems are to be installed in accordance with NFPA 13 and PRC.12.1.1.0 as modified by this guideline.

Water Supplies

Provide two reliable water supplies; **each one capable of meeting NFPA's design demands for hose stream, ceiling sprinklers, and in-rack sprinklers**. It is not necessary that each supply be capable of meeting AXA XL Risk Consulting's higher design demands that might be expected during a partial impairment of the in-rack sprinkler protection as shown in [Figures 7](#) thru [17](#).

Exterior Piping

Arrange the underground mains as either looped or gridded and valved so that any single impairment (valve closure or piping rupture) would not interrupt both water supplies to the rack area, or affect all of the in-rack protection, or any in-rack protection simultaneously with the ceiling protection. (See [Figure 1](#).)

Interior Piping

Arrange interior piping so that a single impairment will not affect all the in-rack protection or one of the in-rack systems and the ceiling protection. To achieve this goal:

- Feed ceiling sprinklers by a separate riser and feed main from the underground loop (see [Figure 2](#)). Maximum spacing per head for this system is 100 ft² (9.3 m²). The maximum area covered by a system is 40,000 ft² (3720 m²).
Exception: Where a "Checkerboard" ceiling sprinkler system is employed as shown in [Figure 3](#), the ceiling system could be fed by the in-rack risers. Maximum spacing per head for this system is 50 ft² (4.65 m²). The maximum area protected by the two risers is 40,000 ft² (3720 m²) for each set of risers. Each riser should be sized for feeding simultaneously the required ceiling sprinkler density/area of application as well as the required number of in-rack sprinklers.
- Arrange in-rack sprinklers with two separate feeds from the underground loop so that under any credible impairment or single valve closure, no more than 50% of such protection within the warehouse will be affected nor will all the in-rack protection in any one rack be impaired. (See [Figures 2](#) through [6](#).) Locate in-rack sprinklers in accordance with [Figures 7](#) through [17](#), depending upon the commodity class, and if any horizontal barriers are installed.
 - Arrange in-rack sprinkler protection so that no more than one tier level, approximately 5 ft (1.5 m), at the top of the rack will be unprotected, if the ceiling sprinkler system should be impaired.
 - **Exception:** Where a "Checkerboard" ceiling sprinkler system is employed as shown in [Figure 3](#), it is permissible to have 2 tier levels, or approximately 10 ft (3 m) of storage above the top level of in-rack sprinklers.
 - Where a double-fed, single main services all in-rack protection provide valves in all feeds to individual racks. This will permit expeditious handling of localized rack repair, sprinkler replacement, etc.
 - [Figures 7](#) through [17](#) include requirements for in-rack sprinkler pipe sizing. For the purpose of this guideline, the sprinkler pipe is the horizontal branch line supplying the in-rack sprinklers. The riser pipe is the vertical pipe within the rack, which supply the sprinkler pipes. The feed main is the horizontal pipe at the floor or ceiling, which supply the riser pipes.

Supply inside hose connections by a separate feed main from the underground system, or by a separate connection, with a valve and check valve in each connection, to both in-rack system feeds.

Sprinklers

Install ordinary temperature, standard response rated ceiling sprinklers and ordinary temperature, fast response rated in-rack sprinklers.

NOTE: MAXIMUM RELIABILITY contemplates wet pipe sprinklers systems. When the need for a dry or preaction system is encountered, or when the storage arrangement or commodity does not meet the criteria outlined in this guideline, the information regarding the installation should be forwarded to AXA XL Risk Consulting's Account Consultant for review.

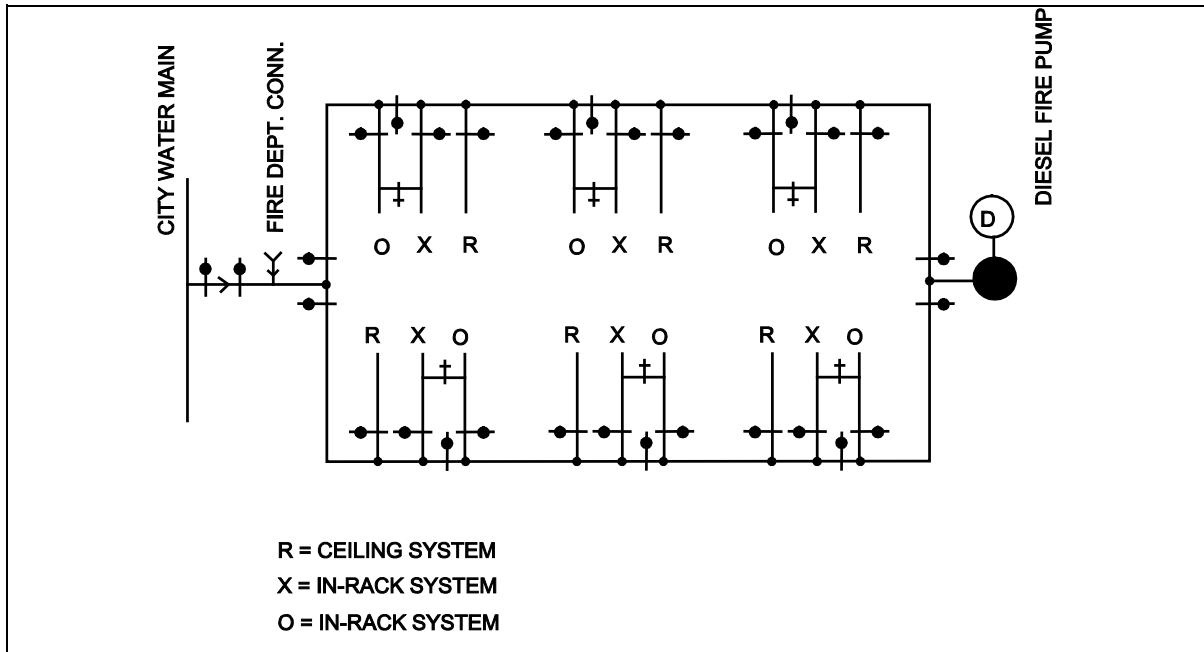

Figure 1. Underground Loop Arrangement.

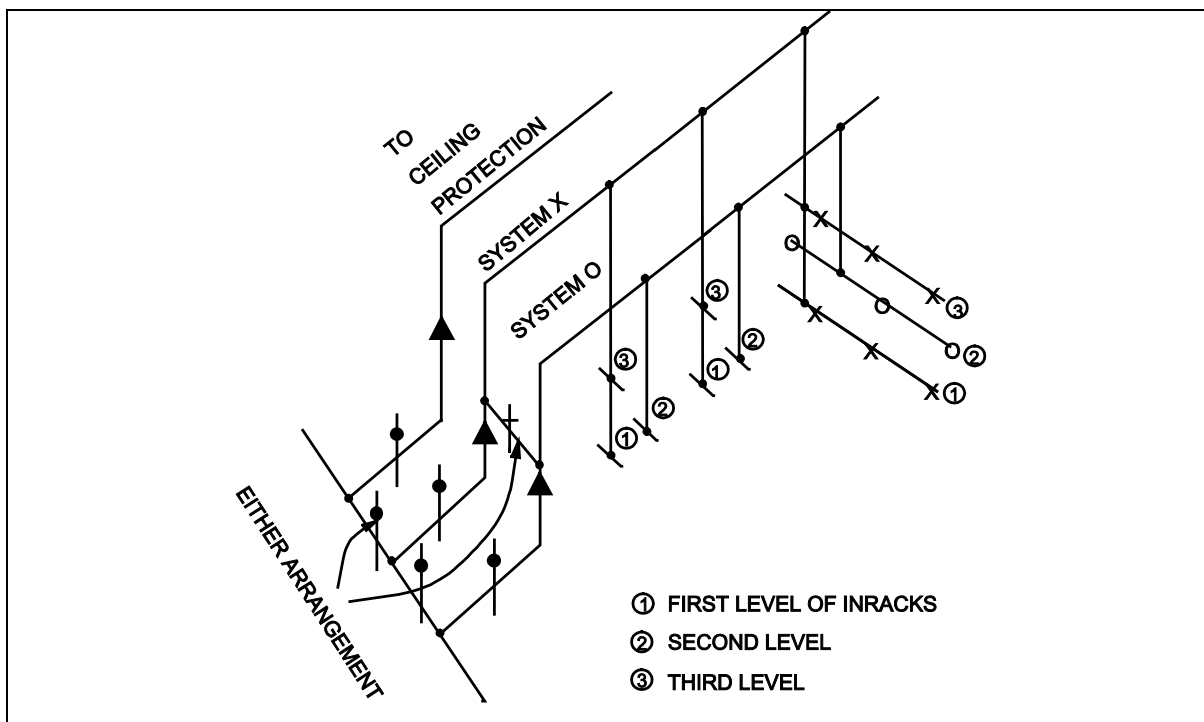

Figure 2. Riser Valving Arrangement For Maximum Reliability.

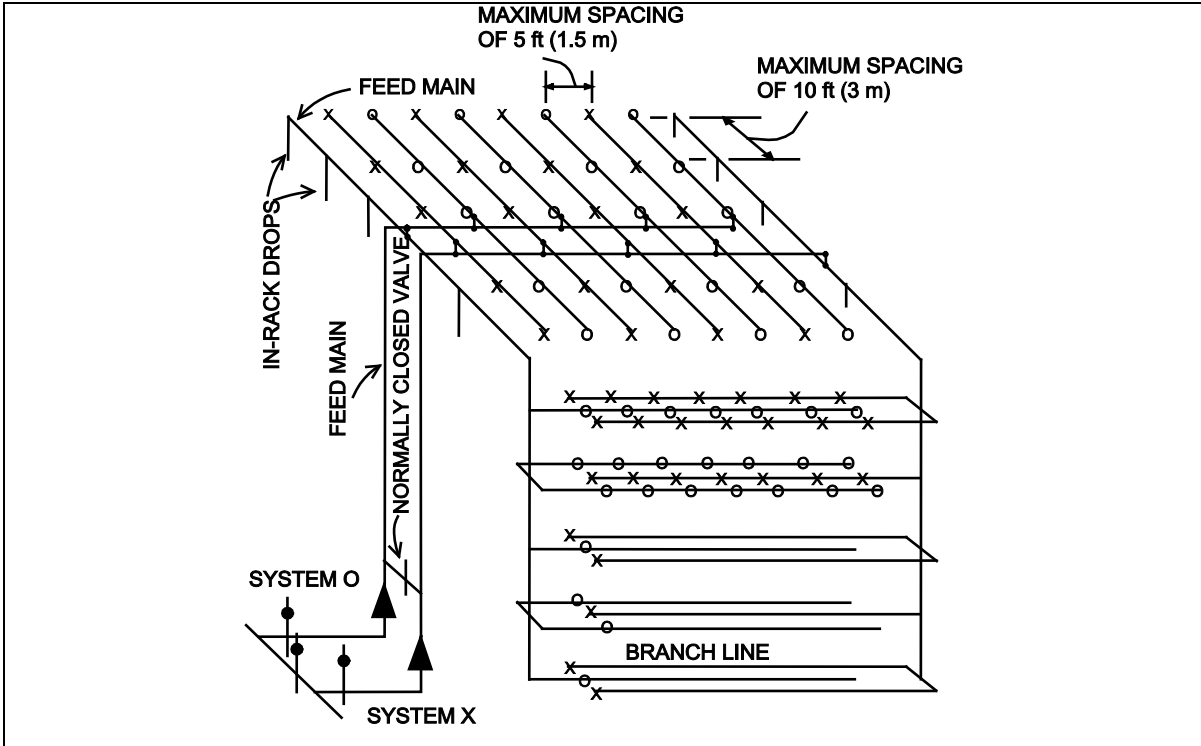

Figure 3. "Checkerboard" Ceiling

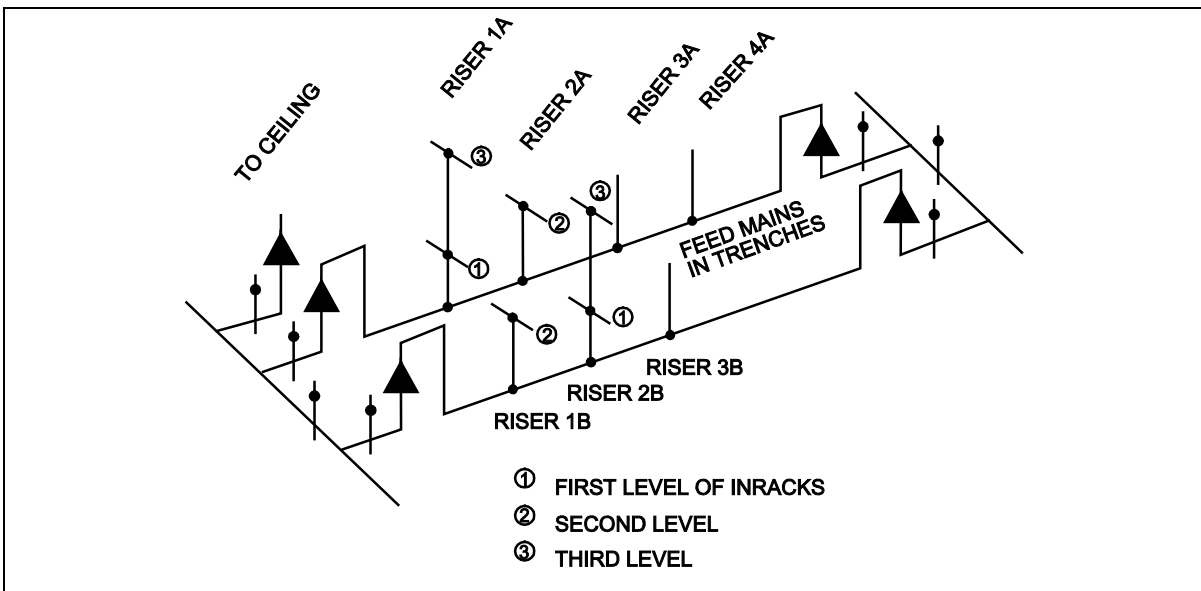

Figure 4. Dual Cross Connect.

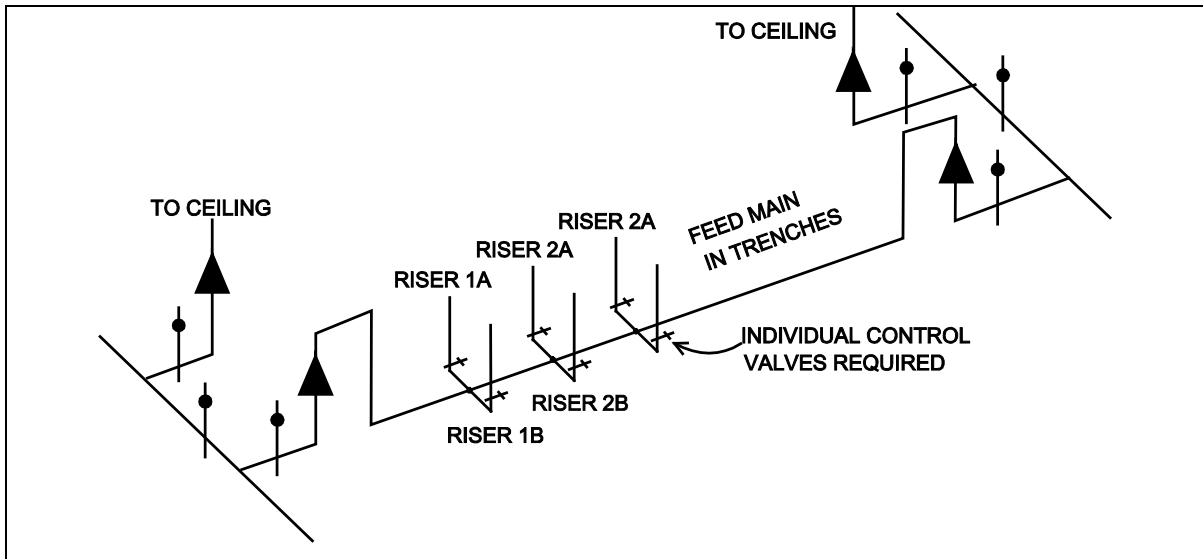

Figure 5. Single Cross Connection.

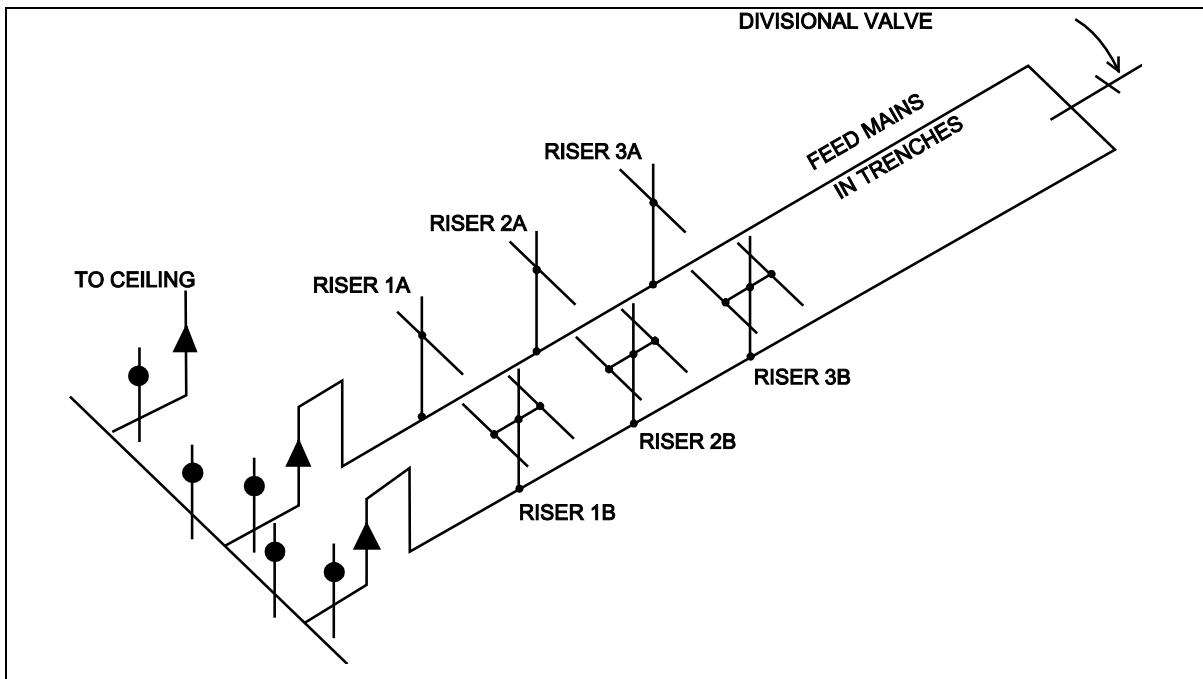

Figure 6. Looped Cross Connect.

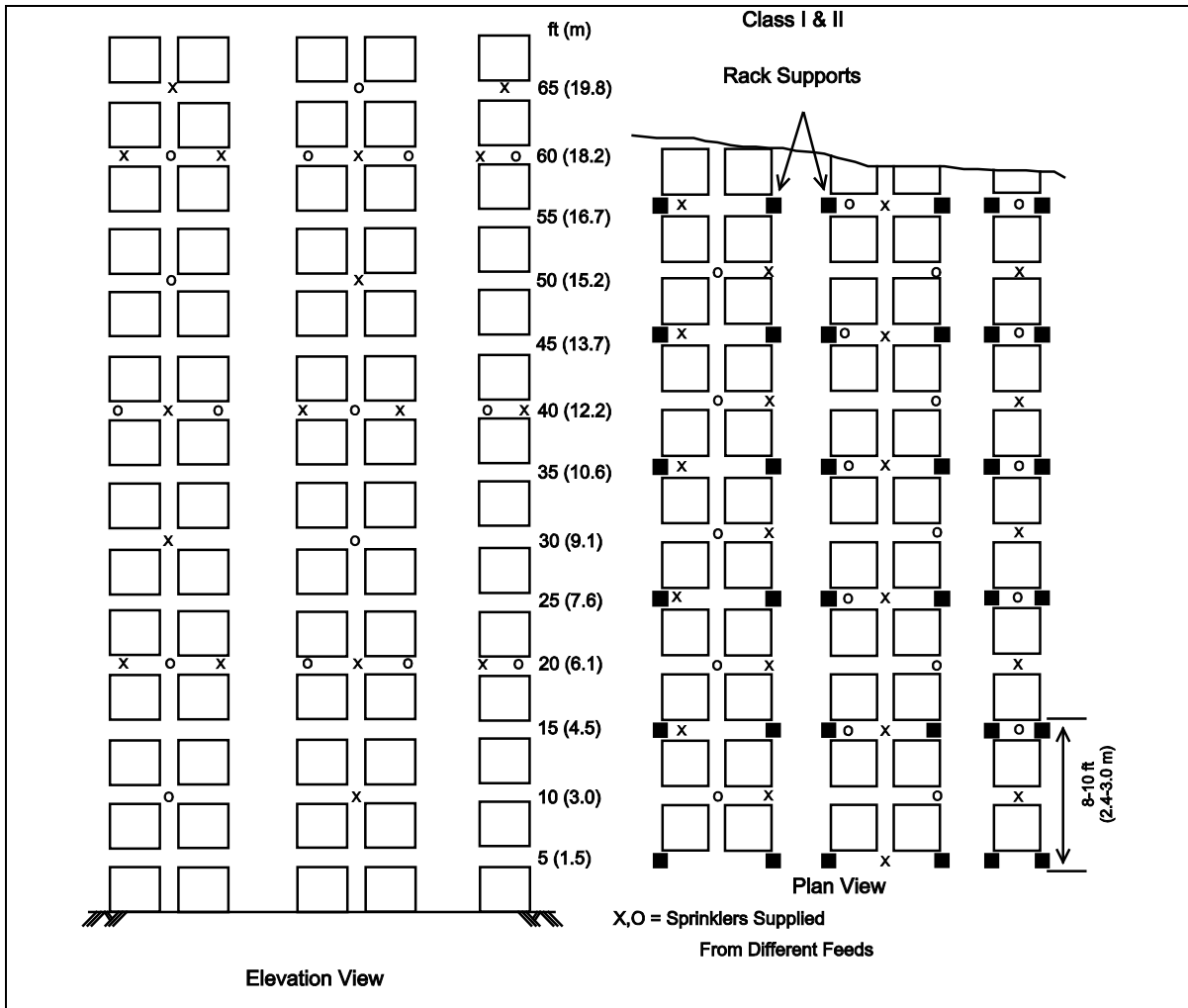

Figure 7. Example of Maximum Reliability for Class I & II Commodities In-Rack Sprinkler Arrangement without Horizontal Barriers.

Water Demand:

Ceiling: 0.30 gpm/ft² over 3000 ft² (12.2 L/min/m² over 279 m²).
 In-rack: 20 sprinklers operating at 30 gpm (113.6 L/min).

Rack Sprinkler Pipe Sizing:

Sprinkler: 7 sprinklers operating at top level.
 Riser: 10 sprinklers operating.
 Feed Main: 20 sprinklers operating.

Other Requirements:

Water Shields: Minimum 5 in. (127 mm) diameter installed over all sprinklers.
 Ceiling Sprinklers: No more than 10 ft (3 m) between top of storage and sprinklers.

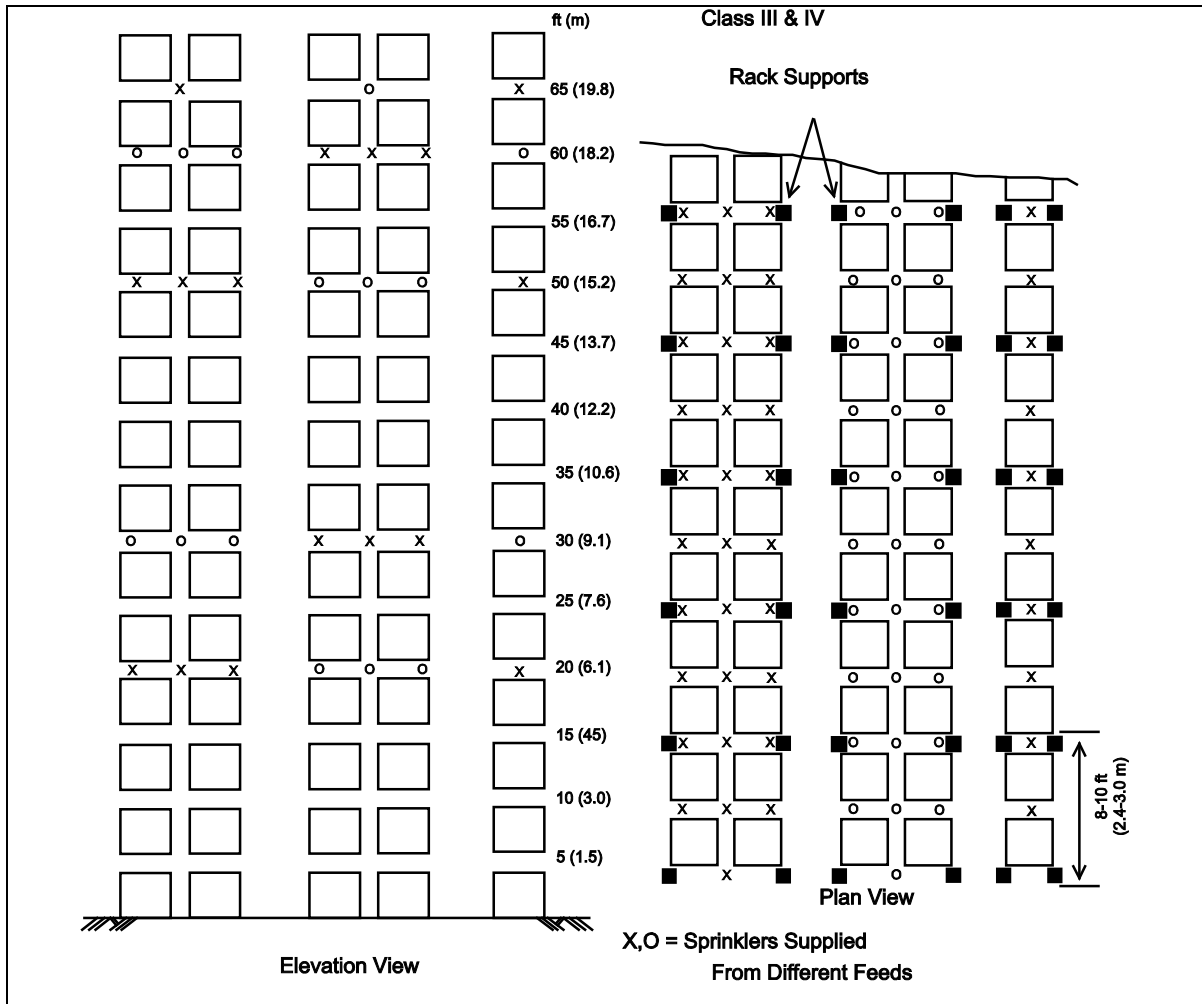

Figure 8. Example of Maximum Reliability for Class III & IV Commodities In-Rack Sprinkler Arrangement without Horizontal Barriers.

Water Demand:	CLASS III	CLASS IV
Ceiling:	0.30 gpm/ft ² (12.2 L/min/m ²) over 3000 ft ² (279 m ²).	0.35 gpm/ft ² (14.3 L/min/m ²) over 3000 ft ² (279 m ²).
In-rack:	20 sprinklers operating at 30 gpm (113.6 L/min).	28 sprinklers operating at 30 gpm (113.6 L/min).
Rack Sprinkler Pipe Sizing:		
Sprinkler:	7 sprinklers operating at top level.	10 sprinklers operating at top level.
Riser:	10 sprinklers operating.	14 sprinklers operating.
Feed Main:	20 sprinklers operating.	28 sprinklers operating.
Other Requirements:		
Water Shields:	Minimum 5 in. (127 mm) diameter installed over all sprinklers.	
Ceiling Sprinklers:	No more than 10 ft (3 m) between top of storage and sprinklers.	

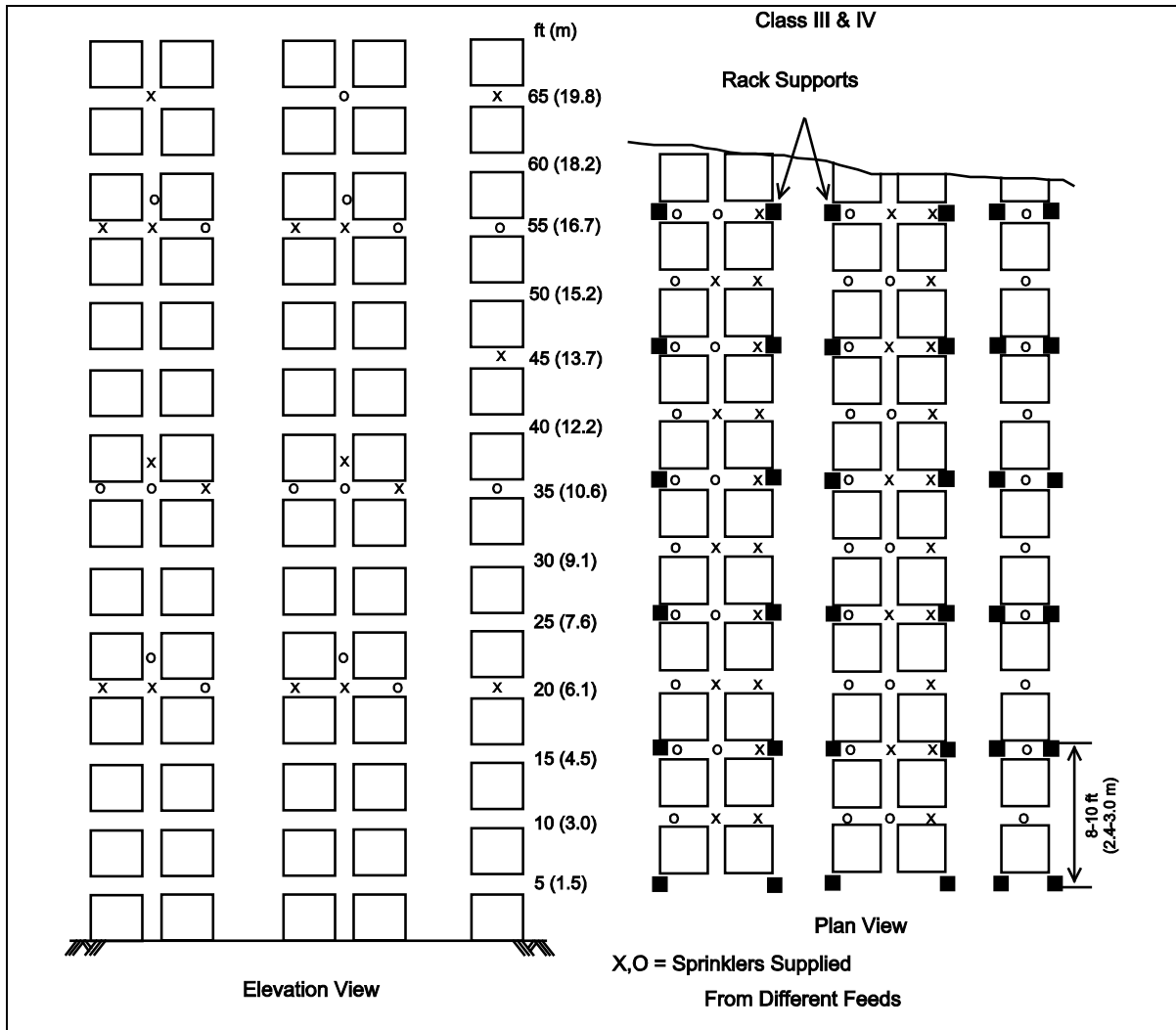

Figure 9. Example of Maximum Reliability for Class III & IV Commodities In-Rack Storage Arrangement without Horizontal Barriers.

Water Demand:	CLASS III	CLASS IV
Ceiling:	0.30 gpm/ft ² (12.2 L/min/m ²) over 3000 ft ² (279 m ²).	0.35 gpm/ft ² (14.3 L/min/m ²) over 3000 ft ² (279 m ²).
In-rack:	20 sprinklers operating at 30 gpm (113.6 L/min).	28 sprinklers operating at 30 gpm (113.6 L/min).
Rack Sprinkler Pipe Sizing:		
Sprinkler:	7 sprinklers operating at top level.	10 sprinklers operating at top level.
Riser:	10 sprinklers operating.	14 sprinklers operating.
Feed Main:	20 sprinklers operating.	28 sprinklers operating.
Other Requirements:		
Water Shields:	Minimum 5 in. (127 mm) diameter installed over all sprinklers.	
Ceiling Sprinklers:	No more than 10 ft (3 m) between top of storage and sprinklers.	

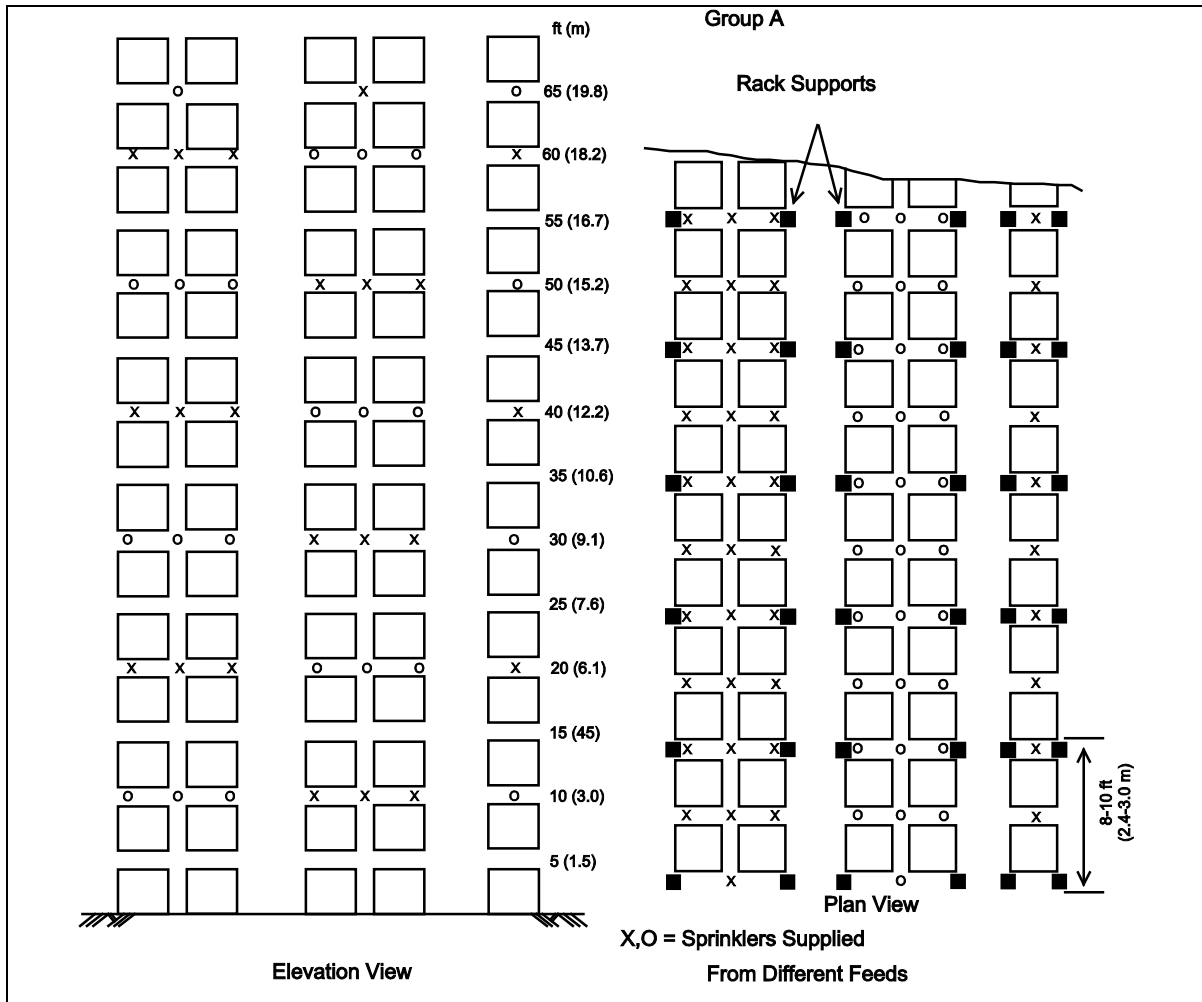

Figure 10. Example of Maximum Reliability for Cartoned Expanded or Cartoned Unexpanded Group A Plastics In-Rack Sprinkler Arrangement without Horizontal Barriers.

Water Demand:

Ceiling: 0.45 gpm/ft² over 3000 ft² (18.3 L/min/m² over 279 m²).
 In-rack: 28 sprinklers operating at 30 gpm (113.6 L/min).

Rack Sprinkler Pipe Sizing:

Sprinkler: 10 sprinklers operating at top level.
 Riser: 14 sprinklers operating.
 Feed Main: 28 sprinklers operating.

Other Requirements:

Water Shields: Minimum 5 in. (127 mm) diameter installed over all sprinklers.
 Ceiling Sprinklers: No more than 10 ft (3 m) between top of storage and sprinklers.

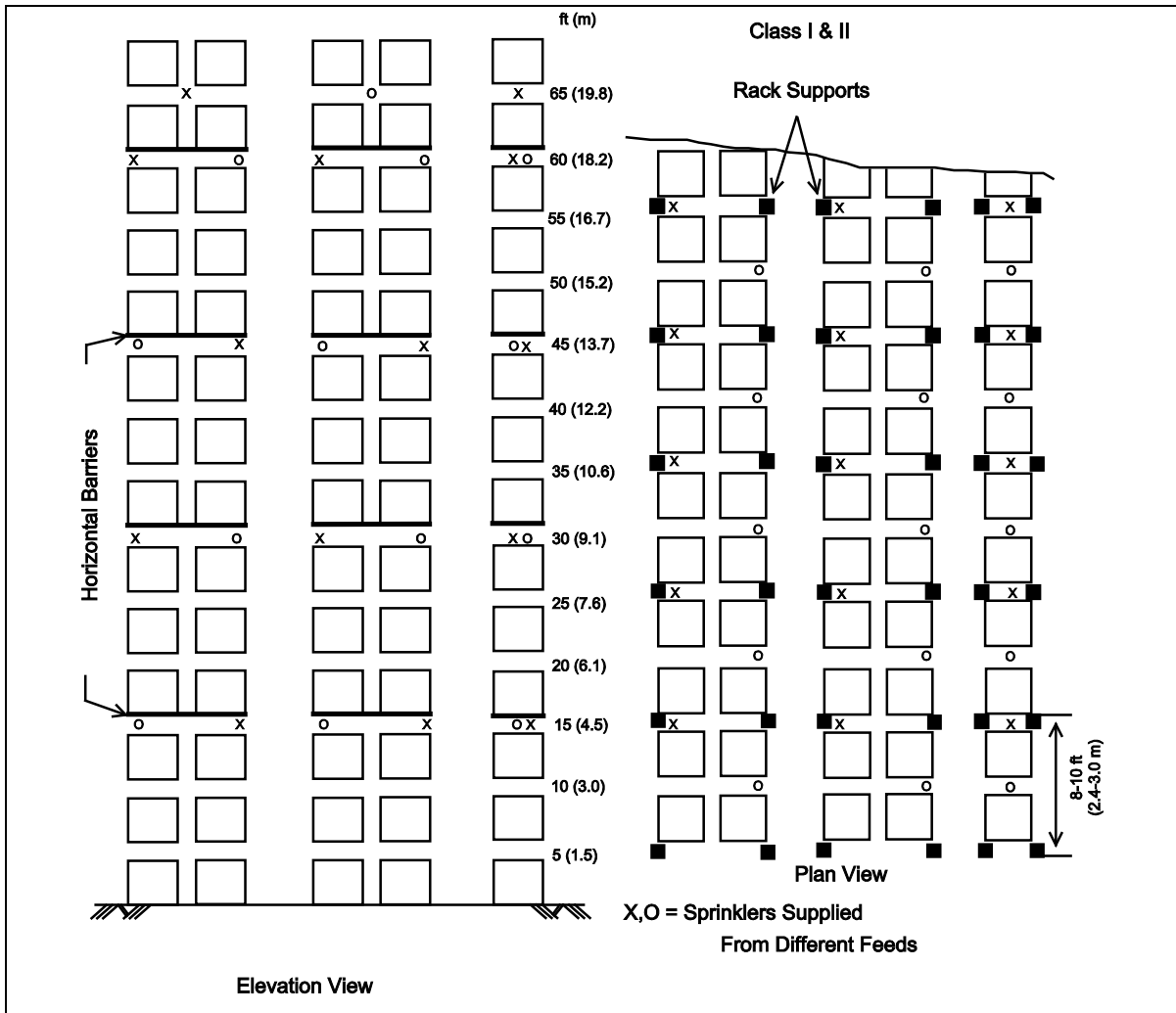

Figure 11. Example of Maximum Reliability for Class I & II Commodities In-Rack Sprinkler Arrangement with Horizontal Barriers.

Water Demand:

Ceiling: 0.30 gpm/ft² over 3000 ft² (12.2 L/min/m² over 279 m²).
 In-rack: 20 sprinklers operating at 30 gpm (113.6 L/min).

Rack Sprinkler Pipe Sizing:

Sprinkler: 7 sprinklers operating at top level.
 Riser: 10 sprinklers operating.
 Feed Main: 20 sprinklers operating.

Other Requirements:

Water Shields: Minimum 5 in. (127 mm) diameter installed over all sprinklers at the top level.
 Horizontal Barriers: 22 gauge (0.78 mm) steel or ½ in. (12.7 mm) plywood covering all flue spaces at 15 ft (4.5 m) maximum increment levels.
 Ceiling Sprinklers: No more than 10 ft (3 m) between top of storage and sprinklers.

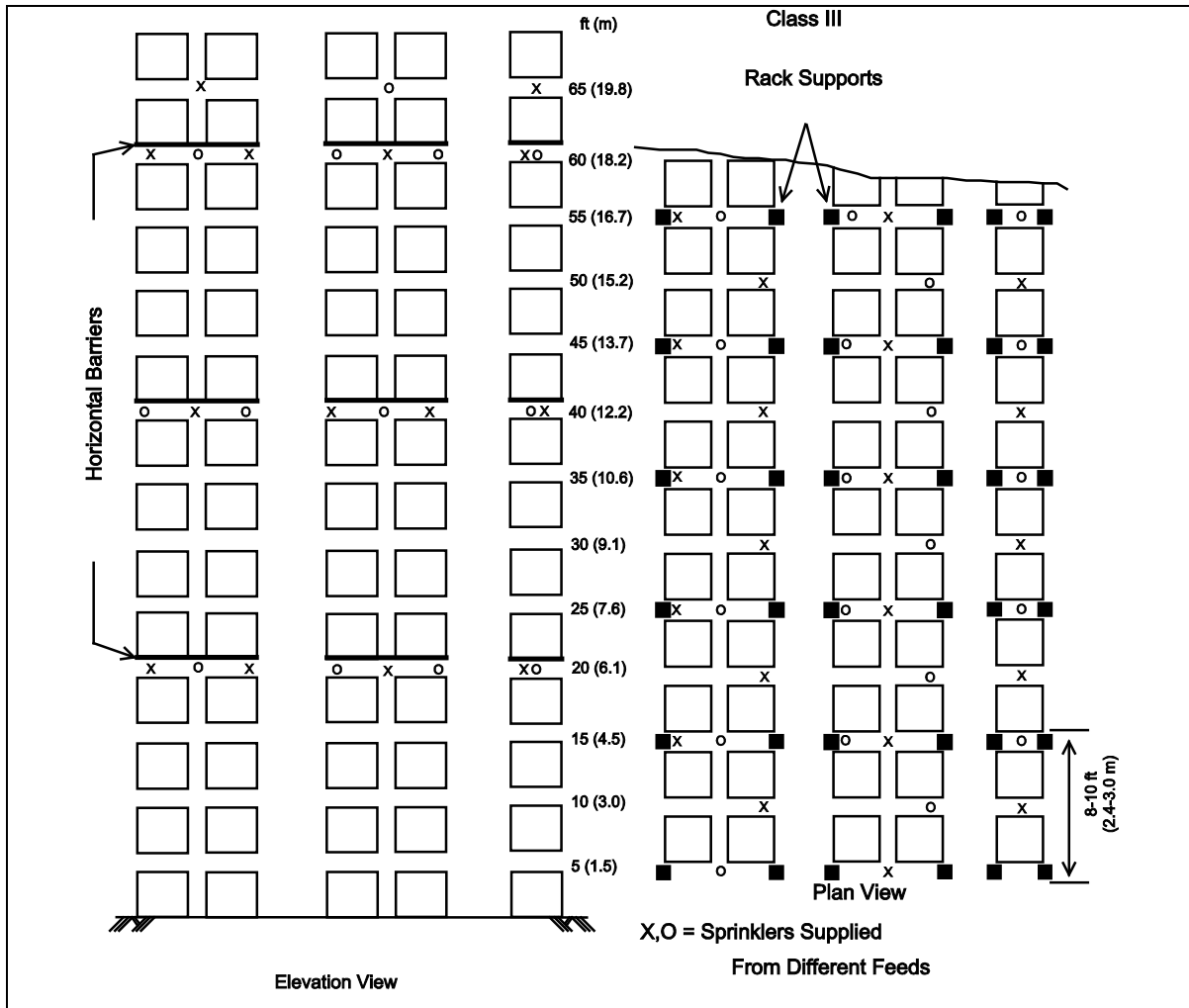

Figure 12. Example of Maximum Reliability for Class III Commodities In-Rack Sprinkler Arrangement with Horizontal Barriers.

Water Demand:

- Ceiling: 0.30 gpm/ft² over 3000 ft² (12.2 L/min/m² over 279 m²).
- In-rack: 20 sprinklers operating at 30 gpm (113.6 L/min).

Rack Sprinkler Pipe Sizing:

- Sprinkler: 7 sprinklers operating at top level.
- Riser: 10 sprinklers operating.
- Feed Main: 20 sprinklers operating.

Other Requirements:

- Water Shields: Minimum 5 in. (127 mm) diameter installed over all sprinklers at the top level.
- Horizontal Barriers: 22 gauge (0.78 mm) steel or ½ in. (12.7 mm) plywood covering all flue spaces at 15 ft (4.5 m) maximum increment levels.
- Ceiling Sprinklers: No more than 10 ft (3 m) between top of storage and sprinklers.

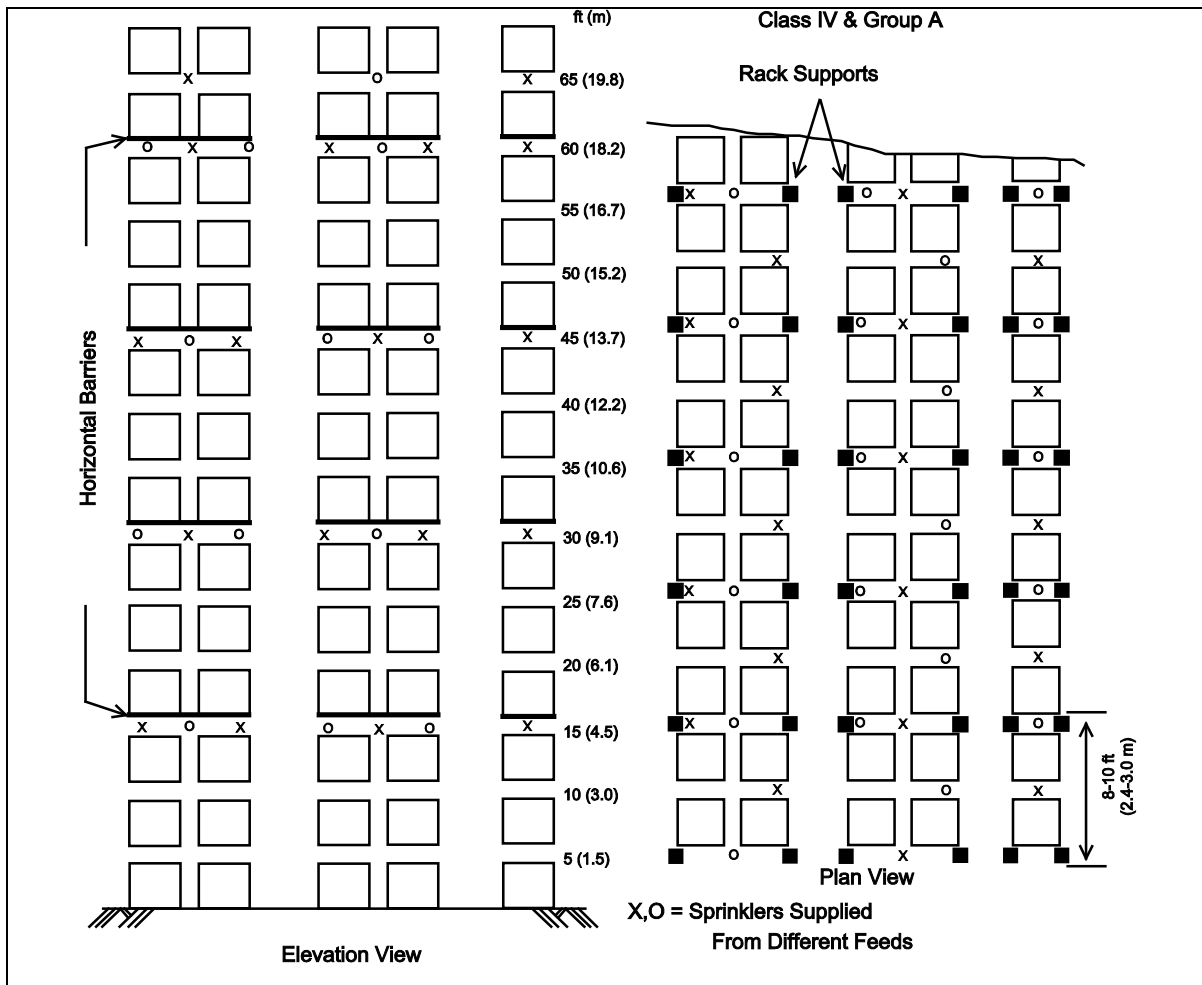

Figure 13. Example of Maximum Reliability for Class IV and Cartoned Expanded and Cartoned Unexpanded Group A Plastics In-Rack Sprinkler Arrangement with Horizontal Barriers.

Water Demand:

Ceiling: 0.45 gpm/ft² over 3000 ft² (18.3 L/min/m² over 279 m²).
 In-rack: 28 sprinklers operating at 30 gpm (113.6 L/min).

Rack Sprinkler Pipe Sizing:

Sprinkler: 10 sprinklers operating at top level.
 Riser: 14 sprinklers operating.
 Feed Main: 28 sprinklers operating.

Other Requirements:

Water Shields: Minimum 5 in. (127 mm) diameter installed over all sprinklers at the top level.
 Horizontal Barriers: 22 gauge (0.78 mm) steel or ½ in. (12.7 mm) plywood covering all flue spaces at 15 ft (4.5 m) maximum increment levels.
 Ceiling Sprinklers: No more than 10 ft (3 m) between top of storage and sprinklers.

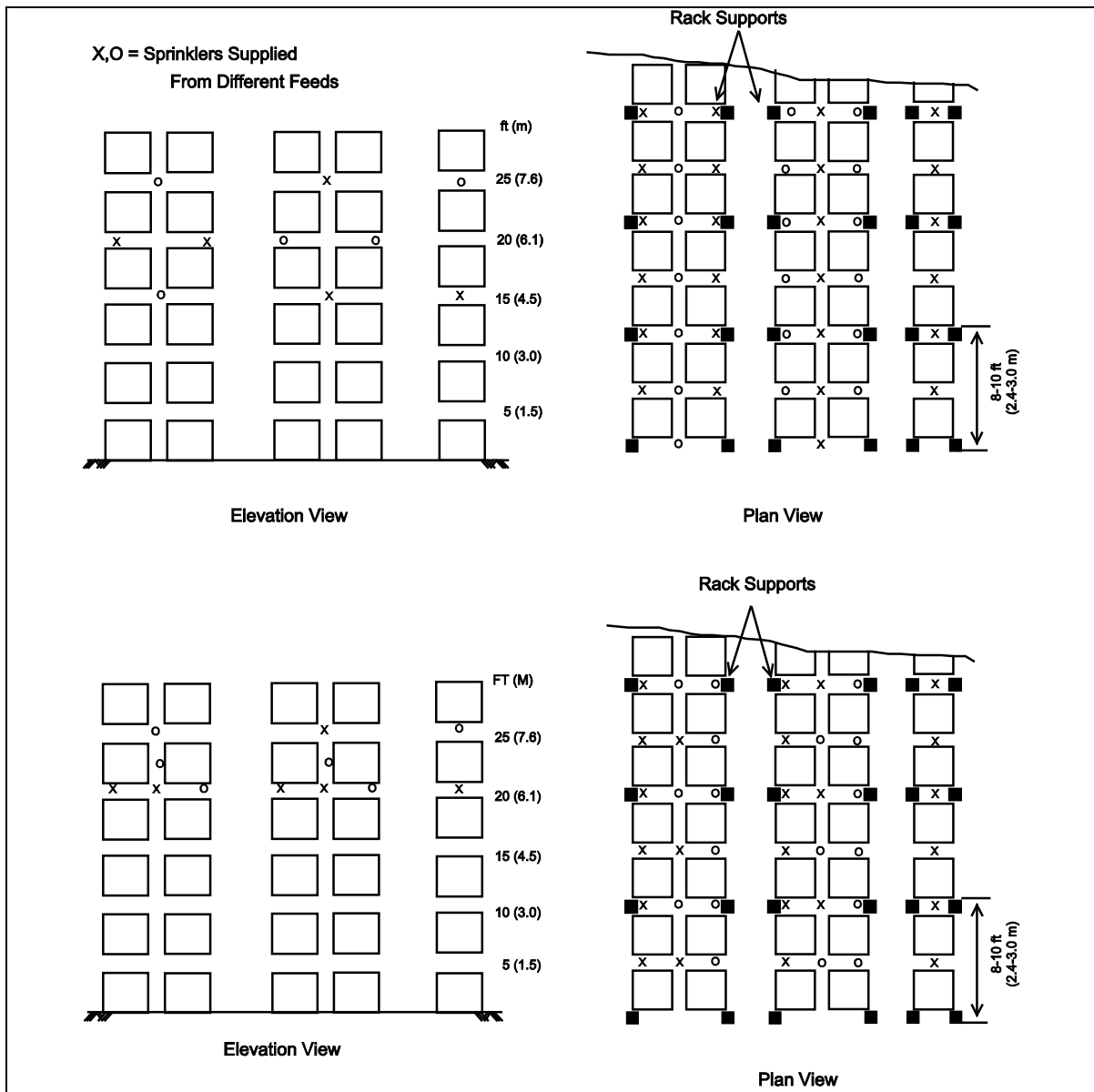

Figure 14. Example of Maximum Reliability for 30 ft High Class III & IV Commodities In-Rack Sprinkler Arrangement without Horizontal Barriers.

Water Demand:	CLASS III	CLASS IV
Ceiling:	0.30 gpm/ft ² (12.2 L/min/m ²) over 3000 ft ² (279 m ²).	0.35 gpm/ft ² (14.3 L/min/m ²) over 3000 ft ² (279 m ²).
In-rack:	20 sprinklers operating at 30 gpm (113.6 L/min).	28 sprinklers operating at 30 gpm (113.6 L/min).
Rack Sprinkler Pipe Sizing:		
Sprinkler:	7 sprinklers operating at top level.	10 sprinklers operating at top level.
Riser:	10 sprinklers operating.	14 sprinklers operating.
Feed Main:	20 sprinklers operating.	28 sprinklers operating.
Other Requirements:		
Water Shields:	Minimum 5 in. (127 mm) diameter installed over all sprinklers.	
Ceiling Sprinklers:	No more than 10 ft (3 m) between top of storage and sprinklers.	

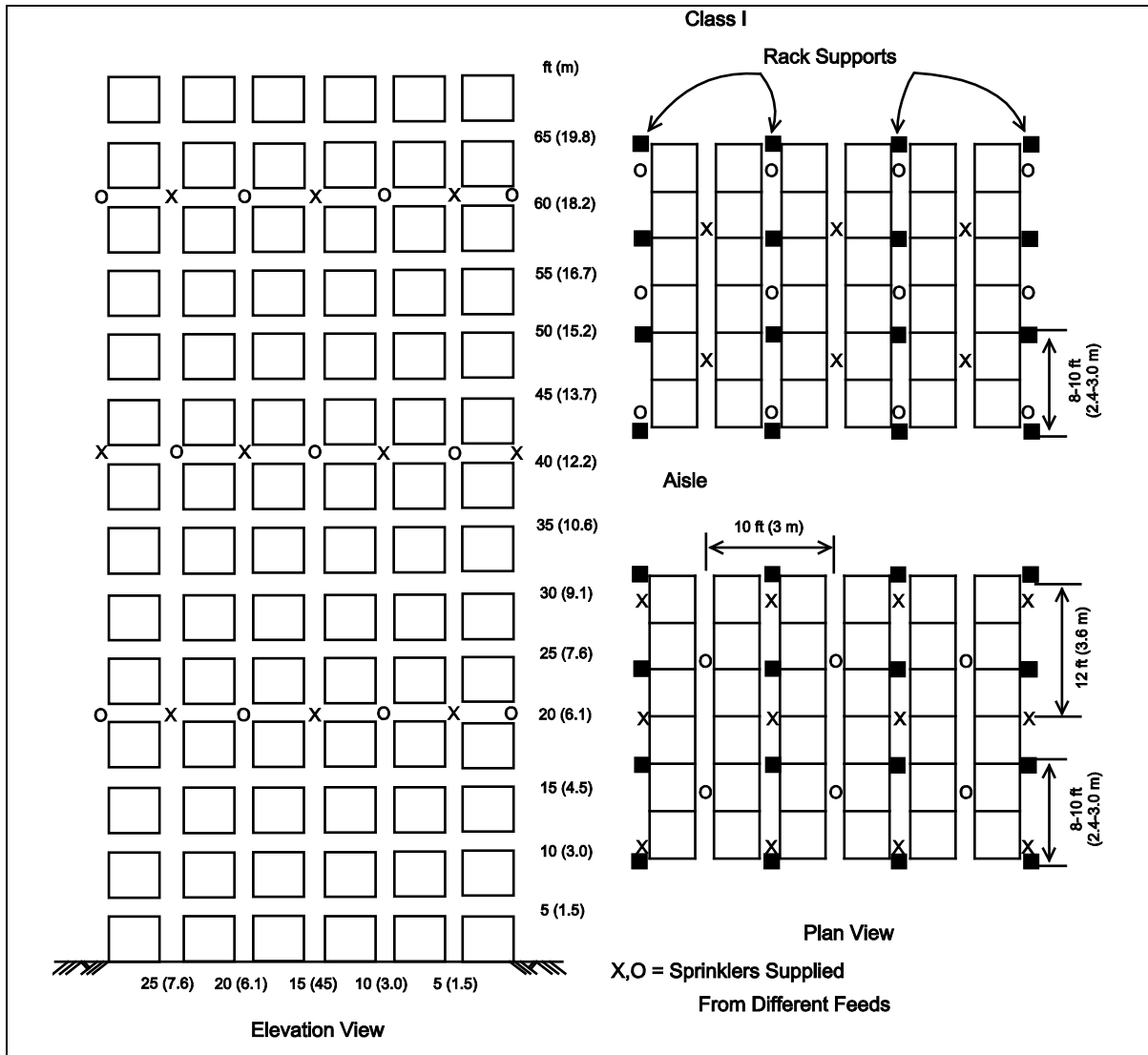

Figure 15. Example of Maximum Reliability for Class I Commodities In-Rack Sprinklers Operating For Multi-Row Racks.

Water Demand:

Ceiling: 0.25 gpm/ft² over 3000 ft² (10.2 L/min/m² over 279 m²).
 In-rack: 20 sprinklers operating at 30 gpm (113.6 L/min).

Rack Sprinkler Pipe Sizing:

Sprinkler: 7 sprinklers operating at top level.
 Riser: 10 sprinklers operating.
 Feed Main: 20 sprinklers operating.

Other Requirements:

Water Shields: Minimum 5 in. (127 mm) diameter installed over all sprinklers.
 Ceiling Sprinklers: No more than 10 ft (3 m) between top of storage and sprinklers.

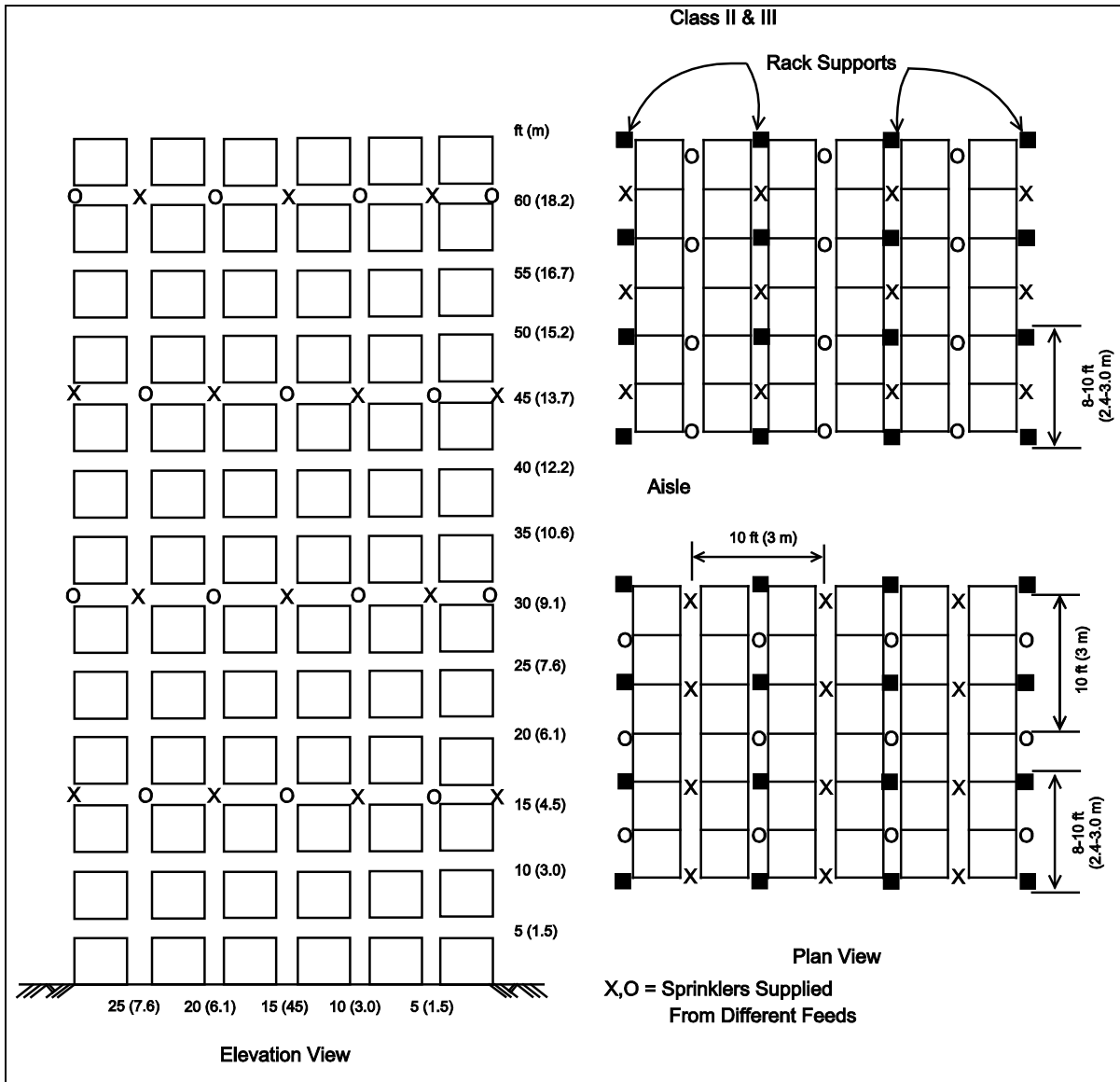

Figure 16. Example of Maximum Reliability for Class II & III Commodities In-Rack Sprinklers for Multi-Row Racks.

Water Demand:

Ceiling: 0.30 gpm/ft² over 3000 ft² (12.2 L/min/m² over 279 m²).
 In-rack: 20 sprinklers operating at 30 gpm (113.6 L/min).

Rack Sprinkler Pipe Sizing:

Sprinkler: 7 sprinklers operating at top level.
 Riser: 10 sprinklers operating.
 Feed Main: 20 sprinklers operating.

Other Requirements:

Water Shields: Minimum 5 in. (127 mm) diameter installed over all sprinklers.
 Ceiling Sprinklers: No more than 10 ft (3 m) between top of storage and sprinklers.

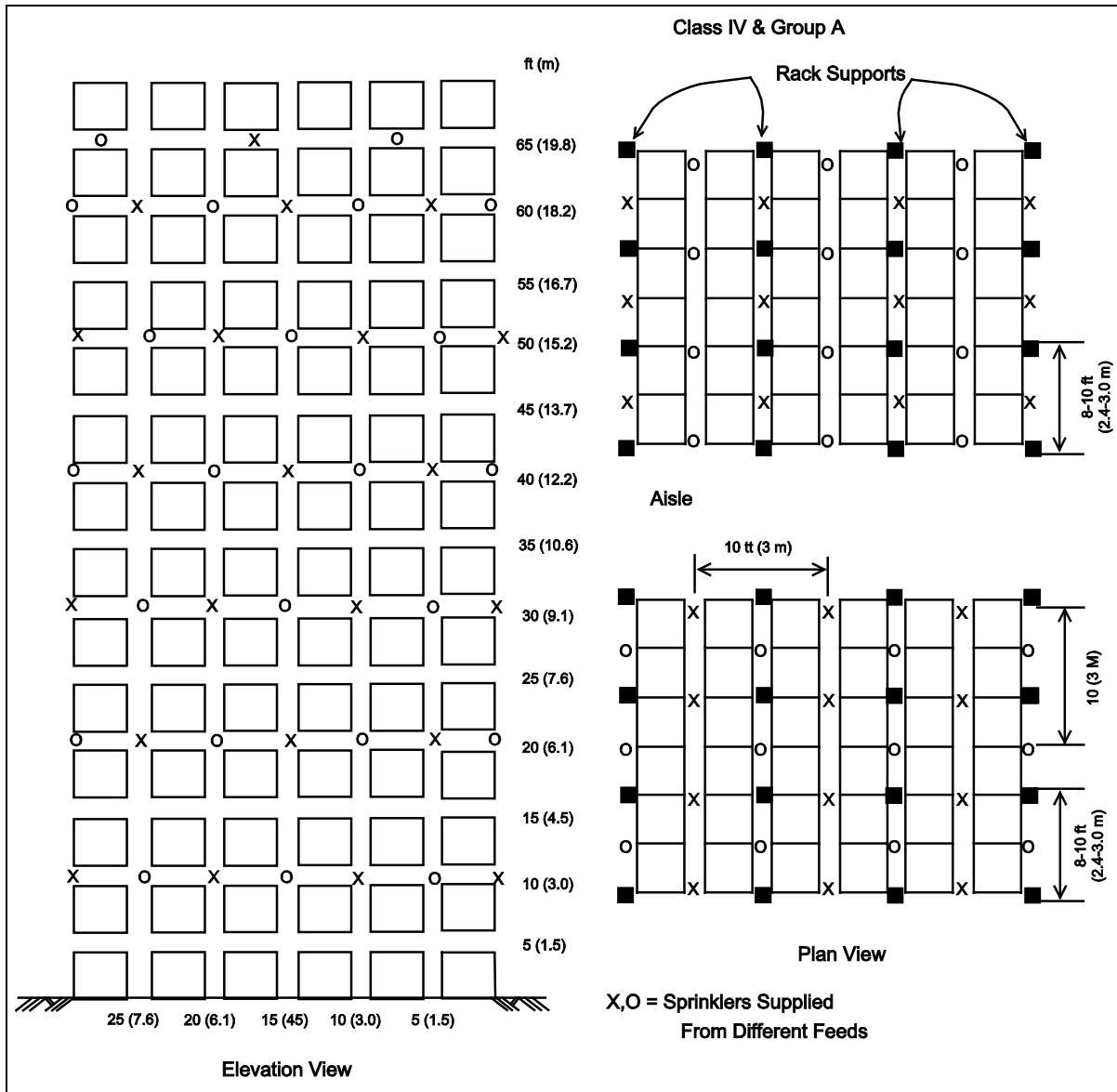

Figure 17. Example of Maximum Reliability for Class IV & Group A Plastics In-Rack Sprinklers For Multi-Row Racks.

Water Demand:

Ceiling: 0.35 gpm/ft² over 3000 ft² (14.3 L/min/m² over 279 m²).
 In-rack: 28 sprinklers operating at 30 gpm (113.6 L/min).

Rack Sprinkler Pipe Sizing:

Sprinkler: 10 sprinklers operating at top level.
 Riser: 14 sprinklers operating.
 Feed Main: 28 sprinklers operating.

Other Requirements:

Water Shields: Minimum 5 in. (127 mm) diameter installed over all sprinklers.
 Ceiling Sprinklers: No more than 10 ft (3 m) between top of storage and sprinklers.